

*Daimler*



Car

F.G. 15 HP.

No 10143

TAMPA BAY  
AUTOMOBILE MUSEUM



The

# Daimler

## Handbook.

BY

JOSEPH A. MACKLE, B.ENG.

THE DAIMLER CO., LTD.,  
COVENTRY.

COPYRIGHT. ENTERED AT STATIONERS' HALL.

## The Daimler Co., Ltd.

Head Office and Works:

COVENTRY.

*Telegrams:* Daimler.  
*Telephone:* 505.

DEPOTS.

LONDON	-	27-28, Pall Mall.	Daimler.	930, Gervard.
..	(Hire Dept.)	78, Marylebone Lane.	Daimlerdom.	10223, Central.
..	(Repair Dept.)	Highgate Hill, N.	Unpassable.	3060, North.
MANCHESTER	-	60, Deansgate.	Daimler.	1583, Central.
..	(Repair Dept.)	Greengate, Salford.	Automobile.	611, Central.
NOTTINGHAM	-	98, Derby Road.	Daimler.	2997.
BIRMINGHAM	-	Sparkbrook.	Daimler.	6532.
BRISTOL	..	61, Victoria Street.	Daimler.	3860.
BRIGHTON	..	Palmeira Works, Hove.	Daimler.	2682, Hove.
LEEDS	..	82, Albion Street.	Daimler.	4072, Central.
NEWCASTLE	..	Northumberland Street.	Daimler.	4573, Central.
CARDIFF	..	Park Street.	Daimler.	881.
ABERGAVENNY	-	Monmouth Road.	Daimler.	107, Post Office.

## Introduction.

This, the second edition of the Daimler Handbook, has been revised in order that it may be applicable to all the 1911 models. With regard to the scope of this little manual, it has been endeavoured to make it thoroughly comprehensive, while yet not unduly technical. The first section is descriptive and deals with the details of the engine, the transmission gear, and the rest of the chassis. Section II. concerns the lubrication of the various parts which require periodical attention, and this chapter should be carefully perused. Then there is a chapter dealing with the driving of the car, followed by a short section on "Troubles and their Location," for, even although slight mishaps and derangements are matters of rare occurrence, it is helpful for the novice to know that full advice and information is readily available. Lastly, the appendix provides miscellaneous information which is likely to prove useful at some time or another.

COVENTRY.

*March, 1911.*

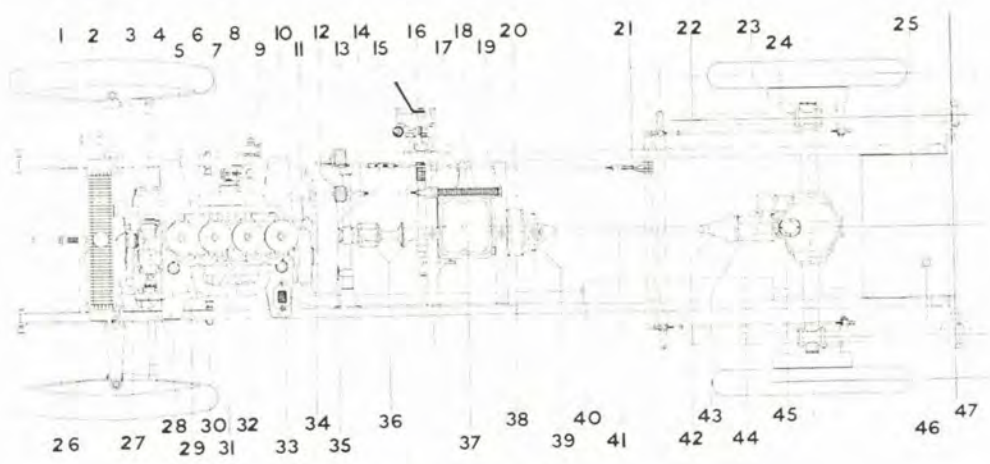

PLAN OF CAR.

PLAN OF CAR.

- (1.) Starting Handle.
- (2.) Steering Arm.
- (3.) .. Rod.
- (4.) .. Connecting Rod.
- (5.) Magneto.
- (6.) Water Outlet Pipe.
- (7.) Carburettor.
- (8.) Induction Pipe.
- (9.) Steering Box.
- (10.) Steering Lever.
- (11.) Ignition Plug.
- (12.) Clutch Pedal.
- (13.) Brake Pedal
- (14.) Clutch.
- (15.) Steering Column.
- (16.) Change Speed Lever.
- (17.) Brake Lever.

- (18.) Clutch Spring.
- (19.) Spring Adjusting Nut.
- (20.) Hand Brake Adjusting Rod.
- (21.) Foot Brake Equalising Links.
- (22.) Rear Spring.
- (23.) Foot Brake.
- (24.) Spring Clips.
- (25.) Petrol Tank.
- (26.) Radiator Filling Cap.
- (27.) Fan.
- (28.) Water Pump.
- (29.) Fan Belt Tension Spring.
- (30.) Swivel Spring Shackle.
- (31.) Exhaust Pipe.

- (32.) Detachable Cylinder Head.
- (33.) Oil Filler.
- (34.) Flywheel.
- (35.) Clutch Brake.
- (36.) Flexible Coupling.
- (37.) Gear Box.
- (38.) Brake Drum.
- (39.) Universal Joint.
- (40.) Silencer.
- (41.) Propellor Shaft.
- (42.) Leather Casing.
- (43.) Flexible Coupling.
- (44.) Oil Filler Arm.
- (45.) Inspection Plate.
- (46.) Petrol Tank Filler.
- (47.) Auxiliary Spiral Springs.



SECTION I.

Description of the Working Parts.

In this section the working of the various parts is carefully explained, so that the owner may have a thorough knowledge of the details of his car.

THE ENGINE.

The principal feature of the Daimler engine is the absence of the poppet valves fitted to all other motors. These poppet valves are noisy in action and uncertain in operation, and to them may be attributed quite half of the troubles with which the old type of engine is afflicted. On the Daimler engine, sliding sleeves are fitted—the advantages being, perfect silence,

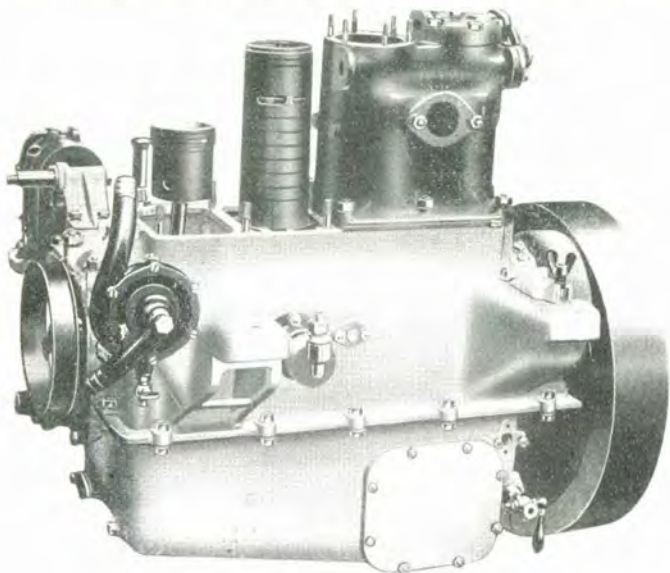

ENGINE PARTLY DISMANTLED.

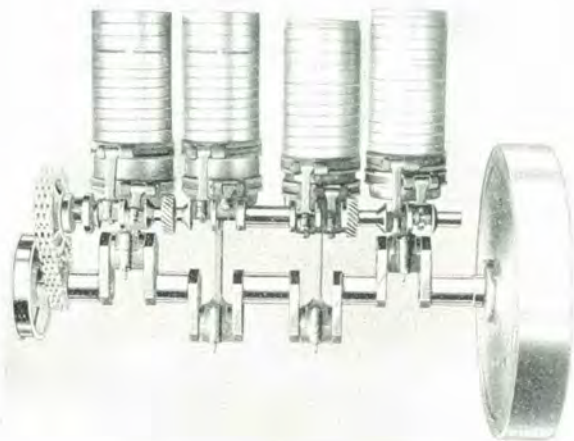

THE SLEEVES AND ECCENTRIC SHAFT.

certainty of operation, absence of wear and of moving parts likely to cause trouble. These points will be obvious to even the most unmechanical observer; but the engineer will quickly recognise the additional advantage of the high thermal and mechanical efficiency which results from the special arrangement of the working parts—an arrangement possible only with the Daimler sleeve valves.

The working of the engine will be easily understood from the following description, which refers to the lettering of the accompanying sectional drawing.

Instead of poppet valves, two moving sleeves, A and B, are made to work together in an outer water-jacketed cylinder. These sliding sleeves are actuated by separate eccentrics on the half-speed shaft, W, through the connecting rods C and D attached by gudgeon pins to the lugs X and Z. L is the water-jacketed cylinder head, resembling an inverted piston,

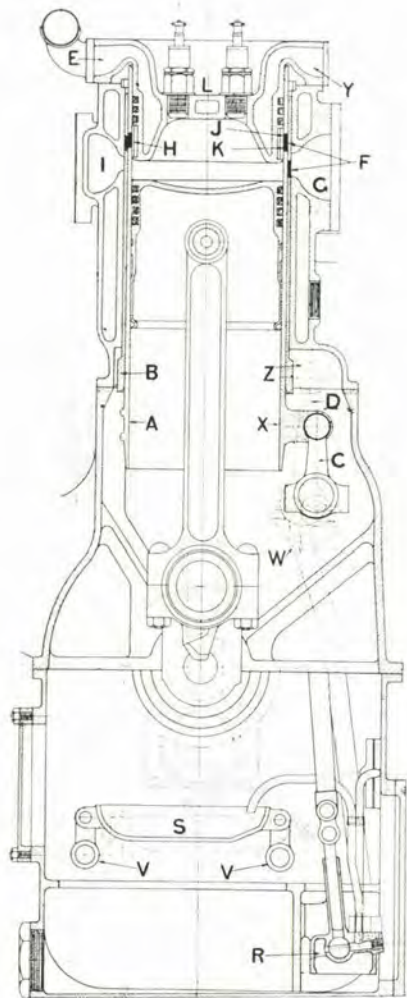

SECTIONAL VIEW OF ENGINE.

and carrying the sparking plugs and a wide packing ring J. This ring is in two halves and is pressed outwards against the inner walls of the sleeve A by an inner ring K, which resembles an ordinary piston ring.

The cycle of operations is as follows. —

The piston travels downwards on the explosion stroke until it reaches the point where it is necessary to exhaust. At this stage the sleeves A and B have moved downward until the lower lip of the exhaust port F of the inner sleeve passes from behind the compression ring K. The continued downward movement of the sleeves A and B brings the two ports F F completely into line with the exhaust port G in the cylinder. This port remains open until the piston reaches the top of the exhaust stroke, when it is closed by the upper lip of the port F in sleeve B telescoping with the lower lip of the exhaust port G in the water-jacketed cylinder.

As the piston starts downwards on the suction stroke, the exhaust ports F F move away from each other, and the opening in A is closed by the wall of B. This same movement brings the two inlet ports H H into register with the cylinder inlet port I, thus enabling the cylinder to be filled with gas from the carburettor.

When the piston moves downwards on the suction stroke, the sleeves have already reached the bottom of their downward stroke and commence to travel upwards, the movement of the sleeve A being so timed as to carry the inner port H upwards behind the ring J just after the piston has reached the lower end of the suction stroke. This closes and tightly seals the cylinder while the piston returns on compression stroke, the ring J pressing tightly over the ports F and H until the explosion occurs, when the cycle of operations is repeated.

To explain the working of the engine in a still clearer manner, a working cardboard model has been designed. The price of this is 1s. 6d., and it may be obtained from the Daimler Co. or from any bookseller or railway bookstall.

DIAGRAMS SHOWING POSITIONS OF SLEEVES AT  
DIFFERENT PARTS OF THE CYCLE.

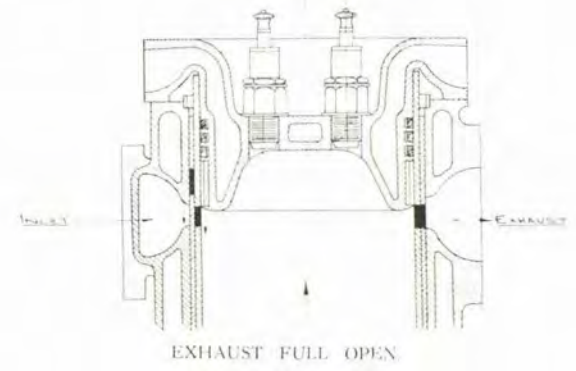
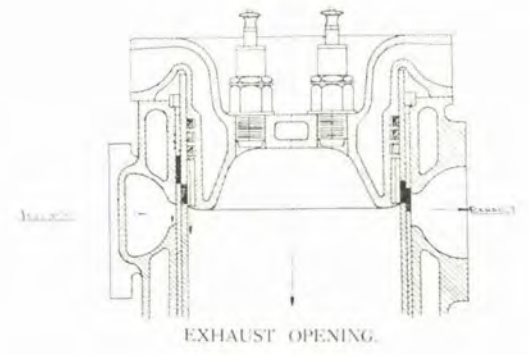
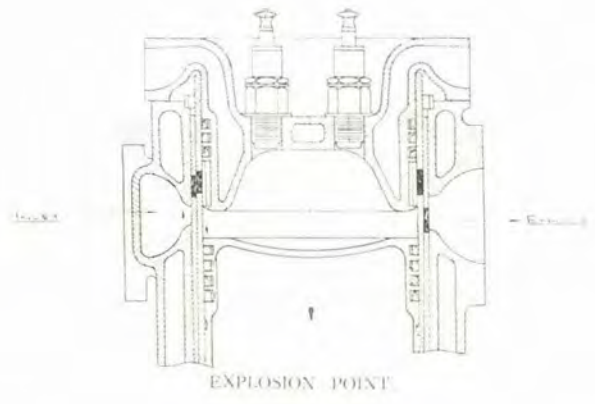
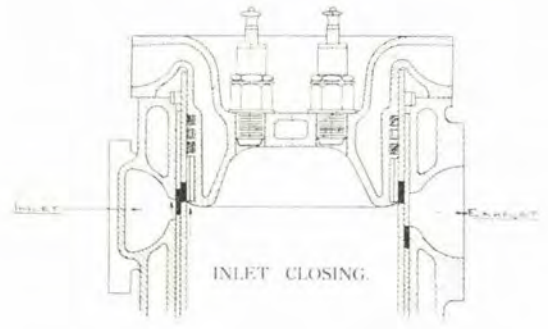
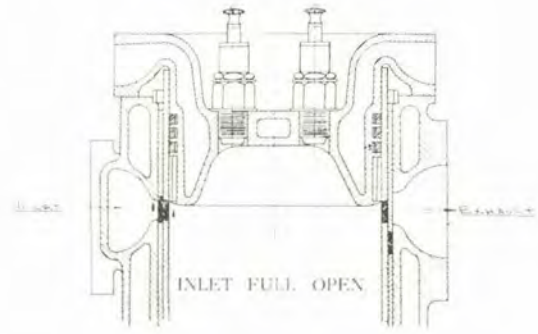
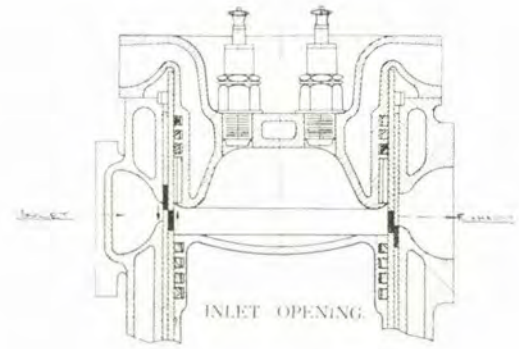

## ENGINE LUBRICATION.

The lubrication of the Daimler engine is arranged on a system which is found to give very satisfactory results. The oil in the crank case drains down to the pump A, which is driven from the eccentric shaft by pump rod B. This pump consists of a set of plungers working in a casing R (see illustration on page 6), and the supply and delivery is controlled by a small rocking valve, also actuated from the eccentric shaft. From the pump the oil is forced through the pipes C, D1, D2, etc., in turn. Of these, C leads to the gauge on the dashboard, so that the driver can always be certain that the oil is circulating properly. The remaining pipes, D1, D2, etc., lead to the troughs E1, E2, etc., which are situated immediately below the connecting rods. As the crank-shaft revolves, the scoops on the connecting rod ends dip into the oil in the troughs and splash it up to the piston, sleeves, and bearings. Afterwards the oil runs back to the pump, passing through the gauze filter G, which serves to collect any dirt which may be present.

Thus it will be seen that the supply of oil to the engine is constant and independent of the amount in the base chamber, provided that the oil does not fall below the level of R (page 6). Normally the level is at the line V.V. (page 6).

Large side inspection covers are provided in the sides of the crank case so that the gauze oil filter and the oil pump are readily accessible. The oil pump can be removed from place without removing the bottom half of the crank case.

A special feature on the 1911 engines is the adjustment of the oil level to suit the varied conditions of running. In the illustration on page 6 it will be noticed that the troughs S can be rocked about the points V.V. so that the troughs are raised or lowered relatively to the connecting

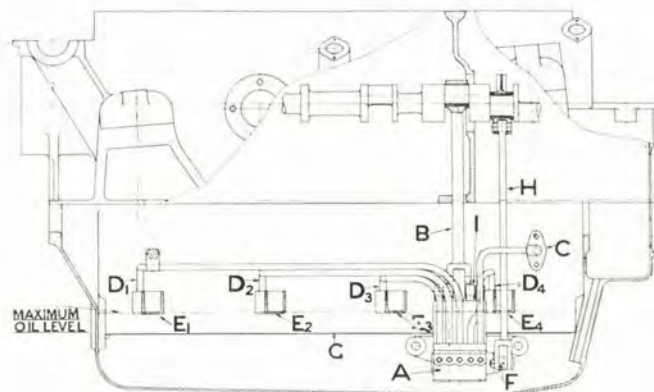

ENGINE LUBRICATION.

rod scoops. This movement of the troughs is regulated by the motion of the throttle lever, so that, when the engine is working at full power, a plentiful supply of oil is given, but when the engine is throttled down, the oil supply is correspondingly reduced. This arrangement gives excellent results.

The gauge on the dash should be so adjusted that the oil just drips at slow speeds. If the oil should drip through the gauge too slowly, the supply may be increased by screwing in the set screw at the rear.





## VALVES.

The sleeves require no attention or adjustment whatever. If the engine should ever be taken to pieces, the only point to be noted when replacing the driving chain is that the correct timing of the eccentric shaft is obtained when the marks on the chain wheels on the eccentric shaft and crankshaft are in line with the respective marks on the adjacent portions of the basechamber wall. An additional check is provided by the fact that the inner sleeve reaches the highest point of its travel when the piston is at the top position on the firing stroke.



## CYLINDER HEADS.

On all cars it is advisable to clean the deposit of burnt oil out of the cylinders at regular intervals, say, after twelve months running. To do this, it is usually necessary to have the engine completely dismantled before the cylinders can be removed.

The Daimler method of fitting detachable cylinder heads renders the operation much more simple. After disconnecting the sparking plug wires, loosen the nuts which connect the water pipes on each side of the cylinder head, and remove the six nuts which hold the head down on the cylinder. The head will then usually be free and may be lifted straight off. If, however, the head is tight in place, leave a couple of the holding down nuts loosely on their studs and then turn the starting handle gently. When the piston rises on the compression stroke the pressure will move the head off its seat, so that it can be lifted off when the nuts have been removed.

## AIR PUMP.

To supply petrol to the carburettor from the tank at the rear of the car, air pressure is employed. This has many advantages over the method of using the pressure of the exhaust gases, as adopted on other cars. In the latter case the pressure is never constant, also, the pipes leading from the exhaust box are apt to become choked up by burnt lubricating oil from the engine. With air pressure, on the other hand, the supply is certain and regular, and there is no possibility of any stoppage of the pipes.

The air pump B (page 14) is placed on the left hand side of the engine and is driven by a short connecting rod from the eccentric shaft. The pump has only two moving parts and cannot possibly give any trouble. The compressed air passes along the delivery pipe D to the petrol tank at the rear of the car. A short branch pipe leads to the pressure gauge E situated on the dashboard within sight of the driver. For normal running, the gauge

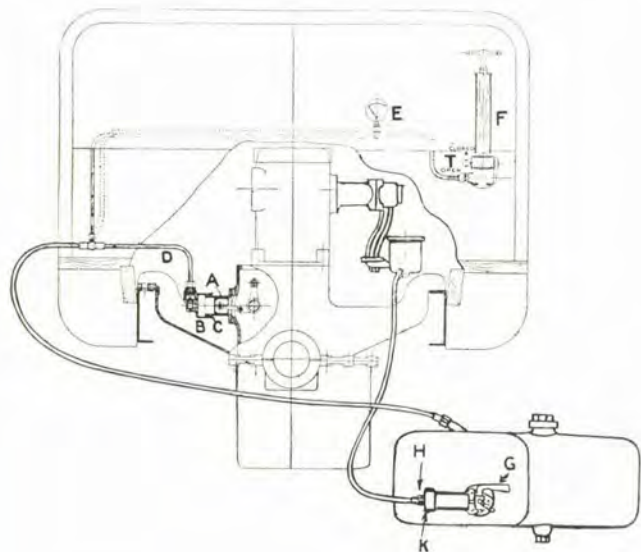

FUEL FEED SYSTEM.

should indicate a pressure of about 3 or 4 lbs. To supply pressure to the tank when starting for the first time during the day, the hand pump F is used. A few strokes of this (with tap T in "closed" position) will raise sufficient pressure to enable the car to be started. When leaving the car for a lengthy period, the tap T should be turned down to the "open" position. This will release the pressure in the tank and prevent any possibility of the petrol leaking out. There is also a tap G provided in the petrol pipe, so that the petrol may be turned off whenever the car is left. This tap will be found at the left-hand side of the petrol tank.



As the supply from the air pump is always constant, there is no need for the troublesome pressure release valve, which is required when exhaust pressure is used. In order that the supply may be adjusted when the car is first turned out, the top of the pump B is screwed on the barrel A, and is locked in any desired position by the nut C. By detaching the air pipe and loosening the nut C, the top portion B may be screwed further on to the barrel to increase the pressure, or unscrewed to decrease it.

#### WATER PUMP.

This pump, which circulates the water used for cooling the engine, is of the centrifugal type. The water from the bottom of the radiator enters at A (page 17) and the revolving vane B forces it outwards until it escapes through the pipe C to the water jackets of the engine cylinders.

To prevent the water leaking through the bearings of the pump spindle D, a gland is formed at E, which is secured by the pressure of the spring G.

If there should be any leakage at the pump spindle, the gland must be repacked. To do this, the nut must be unscrewed, and the spring and brass washer removed, so that the packing can be taken out. A new piece of packing, which can be obtained from the Works or depôts, must then be wrapped uniformly round the spindle, the total length occupied being somewhat more than that of the old packing. When the brass washer, the spring, and the nut have been replaced, the pump will be in good order again for another year's running.

The advantage of the centrifugal pump is that, even when the pump is not revolving, there is a clear passage for water, so that natural circulation is possible. Hence, if the pump should ever jam (not a likely occurrence) the journey could be completed without delay, care being taken, however, to drive with the throttle closed as much as possible.

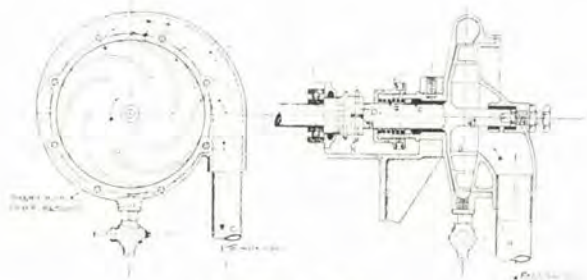

WATER PUMP.

At the lowest point of the pipe leading from the radiator to the pump, a tap is fitted. When the car is left for the night in frosty weather, it is advisable to open this tap and to let all the water drain out. When this has been done, the engine should be run for a few moments to make sure that all the water has been removed. The water in the jackets of the cylinder heads is most conveniently removed by means of the syringe provided with the tool kit. This syringe can be inserted into the jackets by removing the brass plugs in the cylinder heads.

#### RADIATOR.

The new Daimler radiator is made up of flat plain tubes, and its efficiency is such that a comparatively small weight of water need be carried. The hot water comes from the engine by the pipe A to the upper tank B of the radiator, passing thence through the radiator tubes C. These tubes serve to dissipate the heat to the air drawn through the radiator by the fan. The cooled water collects in the lower tank D and from here it passes to the pump by pipe E.

At the filling orifice F a gauze filter G is provided to prevent any dirt passing into the tubes with the water.

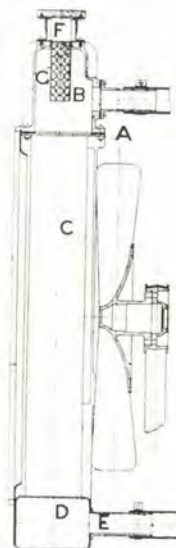

RADIATOR

Apart from actual dirt, however, there is apt to be a gradual incrustation of the system owing to deposition of the carbonates present in the water. This deposit reduces the efficiency of the radiator and may cause the water to boil, and the engine to be overheated in consequence. This incrustation is particularly liable to occur in districts where the water comes from limestone rocks. If the cooling system is to work efficiently, this deposit must be removed at frequent intervals, and the easiest method of effecting this is to drain out the old water and to refill the radiator with a strong solution of common washing soda and caustic soda, in the proportion of four parts to one. Run the car for a day in this way, and then drain out the soda water, afterwards washing out with clean water. To prevent the formation of deposits, rain water should be used when possible.

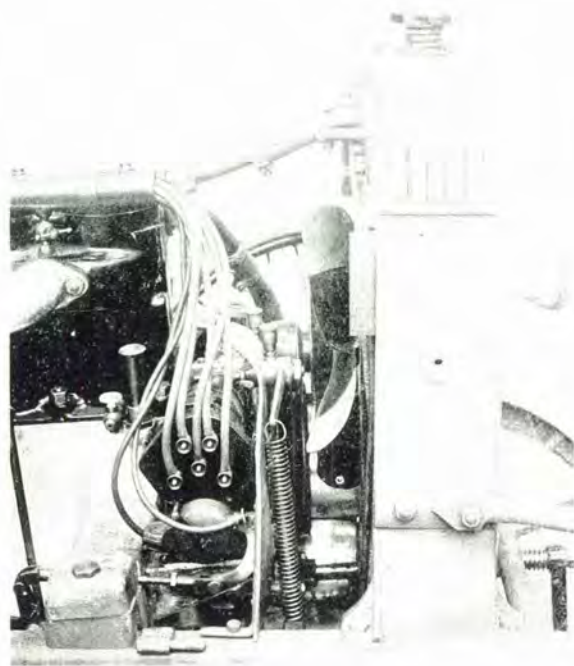

FAN. FAN ARRANGEMENT.

The tubes of the radiator are cooled by the air impinging on them when the car is in rapid motion, but, for slow speeds, and when the car is standing still, the fan is provided to induce a draught through the radiator. This fan is driven by a flat belt from a pulley on the engine shaft. This belt will stretch somewhat after it has been running some time, and for this reason a spring tensioning device is provided to keep the belt sufficiently tight to transmit the drive. After a few months the belt may have stretched so much that the spring can no longer exert any tension on it; when this point is reached, the belt should be removed and shortened, about an inch being taken out of it.



As the fan is designed to revolve at high speeds, the lubrication of the bearings should have frequent attention. This is effected by screwing down the grease caps provided.

#### CARBURETTOR.

The carburettor on the 38 h.p. cars is of the three-jet type, which provides for a much greater variation in engine speeds than does the usual single-jet form.

The petrol flows from the tank at the rear to the float chamber A, where a constant level is maintained by means of the float B and needle valve C. From here a passage leads to the jet chamber D, in which three long jets, E, F, and G, are screwed. These jets project into conical spaces in the top of the carburettor, the object of these spaces being to concentrate the suction on the jets and so to obtain a good flow of petrol at low speeds. The lever K moves the throttle drum H over the top of the conical spaces and over additional air ports cut in the top of the carburettor as shown at P. The arrangement of the latter is such that a correct mixture is supplied to the engine for every position of the throttle.

For starting, and for slow running, only the first jet G is used. As the throttle is opened, the second and larger jet F is uncovered, together with additional air ports, and at the same time the first jet is covered over again. A further movement of the throttle lever brings the third jet E into action, together with the second, these two jets being capable of supplying sufficient fuel to the engine even at the highest speeds. Any further movement of the throttle lever after the third jet has been uncovered serves to supply still more air to the mixture, so that, when the car is travelling with full throttle either up hills or on the level, the correct mixture for these different conditions can be obtained by a slight

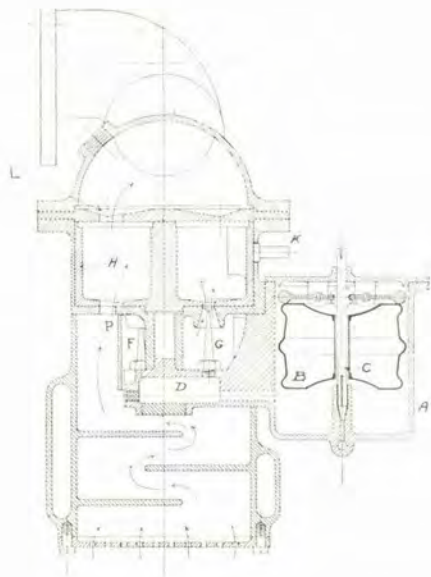

38 H.P. CARBURETTOR.

movement of the lever. On the level all the air may be given, but on hills the supply should be cut down by bringing the throttle lever back a few notches.

To supply additional air to the mixture when necessary, an extra air valve is provided in the inlet pipe, actuated by a foot pedal.



The carburettor fitted to all cars except the 38 h.p. is of the two jet type. In the illustration below, one of the jets is shown detached at A. There are two jets, the smaller one being for slow running and the larger for normal and fast speeds. The jets are screwed into the base B of the float chamber C, and they project up into the tubes D and E. The mixture of petrol vapour and air passes up these tubes to the combined mixing chamber and throttle F, where the requisite additional air is supplied through the ports at G.

To remove the jets for cleaning purposes, the petrol tap must be turned off and the petrol pipe disconnected from the bottom of the float-chamber. Then after unscrewing the nuts which fasten the base B to the crank-case, the float-chamber can be lowered and withdrawn together with the jets. If the jets are removed, care must be taken to replace them in their correct positions.

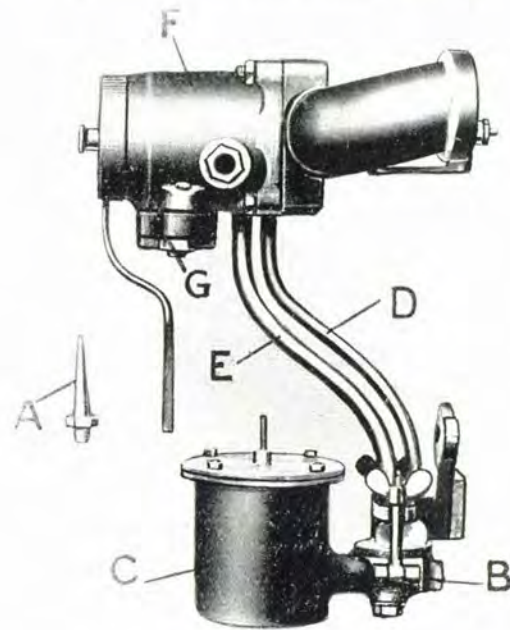

CARBURETTOR-1911 TYPE.

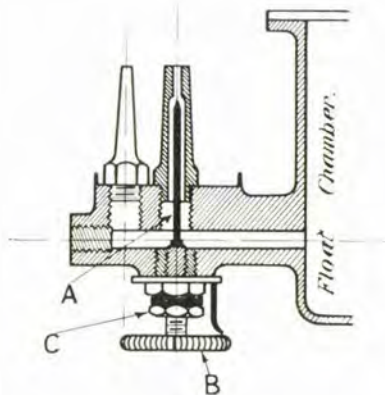

In the carburetors fitted to the 25 h.p. cars, the size of the larger jet is adjustable. The needle valve should be screwed up by turning the milled nut in a right-handed direction as far as possible without lessening the power of the engine. This position will then give most economical results in regard to petrol consumption. The locknut must be carefully tightened up when the correct position has been found.

**PETROL FILTER.**

Stoppage of the jets and dirt in the float chamber are almost entirely obviated by the action of the filter placed in the petrol pipe, at the left of the petrol tank. The filter consists of a thimble of fine gauze, which serves to trap any dirt or water which may have been poured into the petrol tank.

At the end of the filter is situated the petrol tap, and forming part of this is a screwed plug, which enables petrol to be drawn off when necessary. This plug should be tightened up after use and locked in position by the wing nut.

**CAPACITY OF PETROL TANK.**

The approximate amount of petrol which can be carried on each car is :-

15 h.p.	..	9 gallons.	25 h.p.	..	10 gallons.
23 h.p.	..	10 ..	38 h.p.	..	15 ..

**IGNITION.**

Duplicate ignition is fitted on all Daimler cars, the accumulator and coil system being provided for starting purposes, and the magneto for normal running. On the 38 h.p. cars the two systems are separate, but on the other types the C.A.V. or the Bosch Dual Magneto is fitted, wherein the magneto distributor and a single set of sparking plugs are used for both ignitions. How this is effected is explained later.

**38 h.p. CARS.—ACCUMULATOR IGNITION.**

On the 38 h.p. cars the accumulator system follows standard lines, having a low tension distributor and a four-unit coil with a single trembler. The wiring connections are shown in the accompanying drawing. The two accumulators are situated towards the rear of the car beneath the floorboards and they are connected up to a two-way switch on the steering column. The low tension distributor is simple in construction, and not likely to get out of order. The revolving fibre

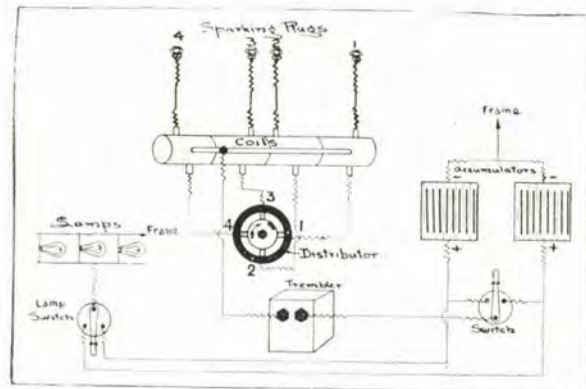

ACCUMULATOR IGNITION WIRING DIAGRAM.

disc on which the four brushes rub should occasionally be wiped clean and afterwards smeared with a drop of oil. The coils require no attention other than to see that the terminals are not loose. The trembler coil is situated in a wooden box beneath the driver's feet. After some time the trembler may require adjustment. This is effected by turning the adjusting screw clockwise a few notches while the trembler is buzzing. Care should be taken not to turn the screw right down to the position of loudest "buzz"; for at this point the consumption of current is excessive. The screw should only be turned down just enough to cause the trembler to buzz steadily. If the platinum points of the blade and screw become badly pitted, these parts should be smoothed up with a fine file.

#### CARE OF ACCUMULATORS.

The accumulators should be recharged at regular intervals—say, every month, but if they are used much, more frequent charging will be necessary. The best method of testing is by means of a voltmeter, which should be connected to the terminals immediately after the accumulator has been in use: otherwise the reading will be no guide as to the true voltage. If the voltmeter reading is below 3·8, the accumulator should be recharged without delay. The maximum charging current must not exceed 6 amperes.

The tops of the accumulators should be kept dry and free from acid. A drop of oil or vaseline on the terminals will prevent corrosion.

If the accumulators are being despatched by rail at any time, they should be packed in a wooden box, open at the top, and labelled "Charged Accumulators."

For making up any shortage of acid in charged accumulators, acid of 1·200 s.g. should be used, unless such shortage has been caused by evaporation, in which case distilled water only should be added.

If an accumulator is received uncharged, it should be filled with diluted acid of 1·225 s.g. made by adding



pure brimstone sulphuric acid to distilled water, *not vice versa*. The acid should be allowed to cool before the accumulator is filled. The charging must be commenced immediately the acid is put in, and continued for at least 36 hours at normal rate (5 to 6 amperes).

When an accumulator is fully charged, the positive plates should be a dark chocolate colour and the negatives a light grey. A whitish deposit is generally a sign that the acid is weak.

#### 38 H.P. CARS.—MAGNETO IGNITION.

These models are fitted with the Bosch Magneto. Brief details are given below, but those who are interested in the details of construction cannot do better than write to the makers for an explanatory booklet.

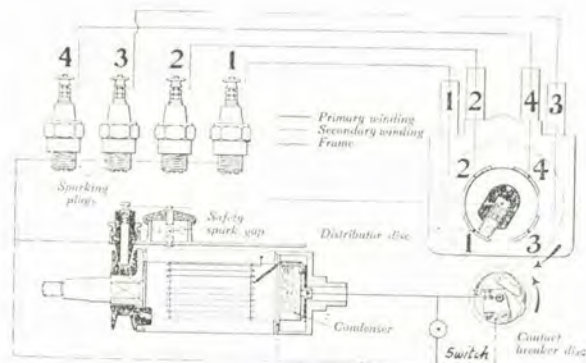

BOSCH MAGNETO WIRING DIAGRAM.

## BOSCH MAGNETO.

The Bosch Magneto fitted to the 38 h.p. cars is the DR1 type. The accompanying diagram shows the wiring connections. The only external wires are those leading from the terminals 1, 2, 3, 4, to the plugs, and the low tension wire from the terminal on the contact breaker to the switch on steering column.

The high tension cables to the magneto end in vulcanite plugs, and on these plugs rings are cut to denote the number of the cylinder to which each belongs—the cylinders being numbered 1, 2, 3, etc., from the

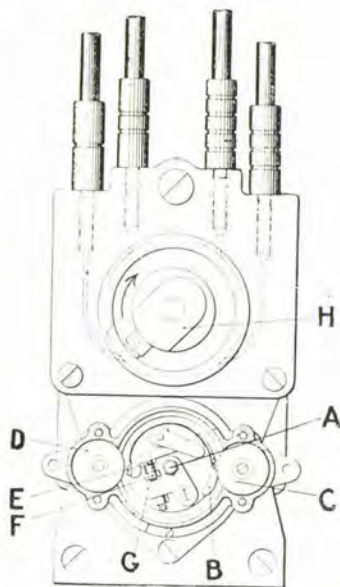

BOSCH MAGNETO CONTACT BREAKER.

front of the car. The plug holes on the magneto are numbered to correspond with the cables.

At each end of the magneto, oil reservoirs with spring lids will be found. A few drops of thin oil should be poured into these about every fortnight. No other part of the magneto requires lubrication, for the contact breaker is so designed that no oil is necessary for the moving parts.

The contact breaker may be described in detail, for the contact screws require attention occasionally. The contact breaker is keyed to the armature shaft, and is kept in place by the screw A; hence, it can be easily removed. When replacing the contact breaker, care must be taken to see that the key is placed in its key-way and that the screw A is well tightened up. As the contact breaker revolves, the lever B comes into contact with the rollers C and D twice in every revolution, and its movement causes the platinum points E and F to separate suddenly. This breaks the flow of the current in the primary circuit and at the same moment the spark is produced at the plug. The points should not separate more than the 0.5 of the millimetre, or one-fiftieth of an inch; if in excess of this, the adjustment can be made by means of the screw G.

Above the contact breaker is the high tension distributor. The revolving distributor piece H receives the current from the armature by means of a slip ring and carbon brush at the other end of the magneto, and distributes it in turn to the four insulated contact pieces, which are connected by the cables to the sparking plugs.



## DUAL MAGNETO.

The dual magneto system gives the advantages of accumulator ignition in regard to ease of starting, together with the admitted superiority of the magneto for normal running, and this combination is obtained with a minimum of parts. In addition to the magneto, only an accumulator and a small trembler coil are required, instead of the accumulator, distributor and large coil which are additional when the two systems are separate.

### C.A.V. DUAL MAGNETO.

The wiring connections are shown in the accompanying diagram. When the magneto is being used, the accumulator and coil are switched out of action and the magneto works as usual. When the accumulator ignition is switched

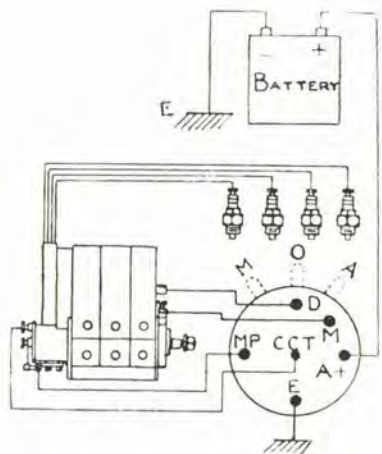

C.A.V. DUAL MAGNETO WIRING DIAGRAM.

on, the low tension switch disconnects the magneto (by short-circuiting the primary winding in the usual way) and switches the accumulator circuit into action, while at the same time the high tension switch disconnects the distributor of the magneto from the secondary magneto wiring and connects it to the secondary winding of the coil. In this way the magneto distributor is used for both ignitions, and likewise, of course, the same set of plugs is used. In the coil actually fitted, the high and low tension switches are worked by a single lever.

The trembler on the coil will require occasional adjustment. This is effected in the same way as described previously on page 24. Similarly the accumulator must have attention at regular intervals.

The wires to the coil terminate in insulated plugs, which fit into sockets in the base of the coil. All these sockets are of different sizes, so that it is impossible to replace the plugs except in the correct positions. The terminals are also marked for convenience in tracing the wiring.

The magneto must be lubricated by pouring a few drops of thin oil into the two lubricators every two or three weeks.

### BOSCH DUAL MAGNETO.

This is somewhat similar in principle to the C.A.V. magneto just described. The wiring connections are shown in the accompanying diagrams, and the respective wires can always be readily traced by their different colours.

To start the engine with the accumulator ignition, the ignition lever on the steering wheel should be moved to its fully retarded position and the coil lever switched over to the position marked A. The engine will still run on the accumulator ignition.

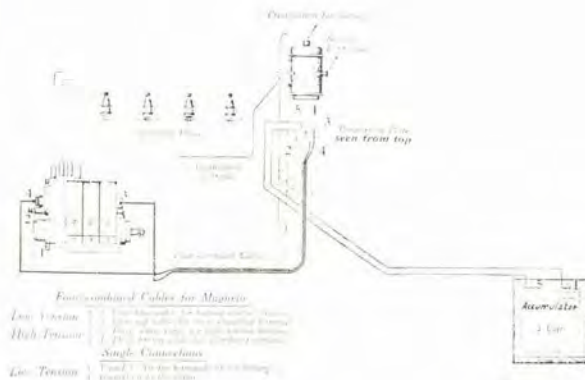

BOSCH DUAL MAGNETO WIRING DIAGRAM

as long as required, but it is better to switch over to the magneto position M, in order to save the accumulators as much as possible.

The lubrication of the magneto should be attended to as described under the heading of Bosch Magneto on page 27. Similarly the same remarks on troubles and adjustments apply, with the addition that every few months the trembler on the coil (accessible by unscrewing the top cover of the brass case) should be adjusted by screwing down the contact screw a quarter turn. As was stated above, the trembler is only used for starting, and it is out of action when the engine is running on magneto ignition; hence the wear of the trembler points is very slight.



## MAGNETO IGNITION TROUBLES.

In the case of the magneto ignition becoming defective, the fault may be in the sparking plugs, in the wiring, or in the magneto itself. If only one cylinder is missing fire, the fault is probably in the sparking plug or cable. The particular cylinder which is "missing" may be located by the method explained on page 80. Possible troubles with sparking plugs are:—

(1.) The sparking gap of the plug may be short-circuited by oil or soot. If this occurs, the plug may be cleaned with a little petrol and a cloth, or, if the plug is very dirty, it may be taken to pieces by unloosening the small lock nut which is situated above the main nut, and the parts can then be thoroughly cleaned before being replaced.

(2.) The spark gap may be too big for the spark to jump across it regularly. The correct distance between the points is only 0.4 of a millimetre, or one-sixty-fourth of an inch. This is much less than is permissible with the accumulator ignition plugs. When the points are set correctly for magneto ignition, it should just be possible to insert a visiting card between them.

(3.) The insulation of the plug may be defective, in which case a new plug will be required.

The cable leading from the magneto terminal to the plug must also be examined to see that the rubber insulation is not damaged at some point, so that the current is short-circuiting to the frame. Similar attention must be paid to the wire leading to the magneto switch.

If the plugs and cables are in good condition, and yet the ignition works irregularly, the defect is probably in the magneto. The contact breaker should first be examined to see that it is working in accordance with

the explanation given under the headings of the different types. Possibly the contact points separate too far, and require to be set closer together. If the points are oily or dirty, they must be cleaned, and, if very uneven, the surfaces must be levelled with a smooth file. After this operation the points will possibly require resetting.

Misfiring may also be caused by dirt on the contact faces of the high tension distributor. This can easily be examined and cleaned.

#### MAGNETO DRIVE.

A flexible coupling is provided between the magneto and the driving shaft. This takes the form of a leather disc, which is bolted alternately to the flange on the magneto shaft and to the flanged end of the driving shaft. The bolt holes on the magneto flange are elongated so as to allow the timing of the magneto to be set accurately, but this should not be altered after the car has left the Works. The two flanges are marked so that there may be no difficulty in correctly replacing the magneto, when this has been removed any time for adjustment.

When the magneto is being replaced, it is advisable to run the engine for a minute or so after the coupling has been bolted up in its proper position, but BEFORE the holding-down strap is tightened. This will enable the magneto to work itself exactly into line with the driving shaft, so that, when the holding-down strap is afterwards made tight, there will be no possibility of a side pull on the magneto bearings.

#### IGNITION. GENERAL HINTS.

The following hints may serve to prevent trouble, or to indicate the cause if it chances to arise:—

(1.) Keep all connections clean, and free from oil. This does not apply to the accumulator terminals, which, as already explained, should have a little grease smeared on them occasionally to prevent corrosion by acid from the cells.

(2.) Keep all wires as far as possible from contact with metal parts, against which they might otherwise rub and so become short-circuited.

(3.) When new sparking plugs are purchased, put these into use right away, and carry the old ones as spares. These old ones were presumably giving good service before, and hence may be relied upon if ever they are required again.

(4.) Keep the points of the spark plugs close together. The old idea of "the longer the spark the stronger the explosion" has been proved to be a fallacy. What is wanted is a short, sharp spark at every speed of the engine, and this is best obtained when the plug points are not more than one-sixty-fourth of an inch apart. A gauge for setting the points to this distance can be made out of a piece of 28 g. sheet brass.

(5.) Failure to start on the switch or difficulty in starting is frequently due to a run-down accumulator or a badly adjusted coil trembler.

#### FIRING ORDER OF CYLINDERS.

Denoting the cylinders by the numbers 1, 2, 3, etc., commencing from the forward or radiator end, the order of firing for the four cylinder engines is 1, 2, 4, 3, while for the six cylinder engines the order 1, 5, 3, 6, 2, 4 is followed.

#### ELECTRIC LAMPS.

The use of electric side and tail lamps was first introduced by the Daimler Co., and these are fitted to all standard cars. The three lamps are connected each by a single wire to the central terminal of the lamp switch, which is situated on the extreme right of the dashboard. The other two switch terminals are connected to the positive terminals of the two accumulators, so that

either may be used at will. To save unnecessary wiring, an insulated block is fitted on the front of the dashboard beneath the bonnet, and the two terminals of this are connected to the positive terminals of the two accumulators and also the two terminals of both the ignition and lamp switches.

The lamp bulbs are specially constructed for car work and are, therefore, not likely to give much trouble. To guard against mishaps, two spare bulbs should be carefully packed in cotton wool and carried on the car. The front of the lamps can be unscrewed to allow access to the bulbs.



## Transmission Gear.

### CLUTCH.

The clutch fitted to the Daimler cars is of the leather cone type, but improved in detail. The leather cone clutch has stood the test of time, and it is now generally admitted that this is the only type which will give uniform results with a minimum of attention. The arrangement of the parts is shown in the accompanying illustration. The main portion of the clutch is of aluminium and is shown at A. This is bolted to the clutch shaft B, which is in turn supported by an extension of the crank shaft C, a long gunmetal bearing D being

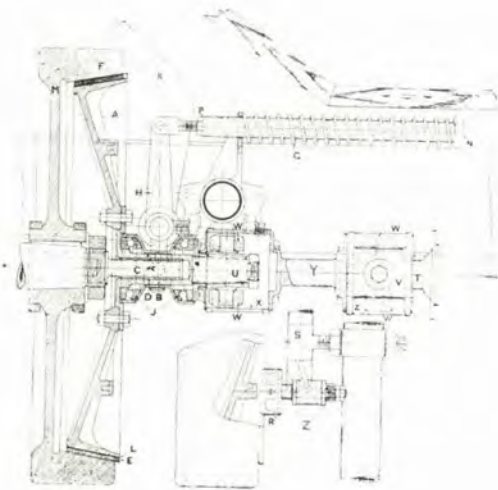

CLUTCH ARRANGEMENT.

fitted to prevent wear. The outer part of the aluminium clutch casting is turned to the shape of a cone, and on this is fitted the leather face E, which fits accurately into the conical recess in the flywheel F. Normally the clutch is pressed into contact with the flywheel by means of the spring G, which pulls on the lever H, and so transmits the pressure of the clutch through the thrust bearing J. When the clutch pedal K is pushed forward, the clutch shaft is moved backwards, and the clutch comes out of engagement with the flywheel. To ensure smooth starting, a flat spring L is placed under the leather. This raises the forward edge and enables it to take up part of the drive gradually, before the main portion of the clutch comes into engagement.

#### CLUTCH BRAKE.

When the engine is revolving at high speed and the clutch pedal is depressed (as, for example, when the car is being started from rest), the clutch tends to keep revolving for a few moments by reason of its inertia. To avoid the necessity of waiting until the clutch has stopped spinning before engaging first speed, the clutch brake R is fitted. When the clutch pedal is depressed, the clutch is moved backwards till it comes into contact with R. This quickly checks the momentum of the revolving clutch and the gears can be engaged without noise. The clutch brake can be adjusted by means of the nuts Z Z and it should be moved along when the clutch has worn somewhat, so that it just comes into engagement when the clutch pedal is fully depressed.

#### CLUTCH ADJUSTMENT.

After continued use, there is naturally a certain amount of wear of the leather face, but this is automatically compensated for by the clutch moving further into the flywheel. Eventually this forward movement

will be limited by the front portion of the cone coming into contact with the flywheel face at M, and, when this state is reached, the clutch must be re-leathered. The clutch should be returned to the Works for the operation, which requires one day's time. With ordinary use the clutch should not require re-leathering before the car has run 30,000 miles.

When the clutch has moved further into the flywheel it will be necessary to keep the spring pressure up to its original value. This is done by loosening the lock nut P and screwing up the nut N several turns. After this operation the lock nut P must be tightened up again.

#### CLUTCH FIERCE.

When the car is first delivered, the clutch leather is in a soft and pliable condition, but after a time it tends to become hard, owing to the heat generated when the clutch is used. This state is usually indicated by the fierceness of the clutch when the car is being started, or by a singing noise when the clutch is let in. To make the leather soft again, a little paraffin or castor oil should be applied on the inner edge of the leather through the arms of the clutch; but excess should be avoided.

#### CLUTCH SLIPPING.

If the clutch should slip and be unable to transmit the power of the engine, particularly when on a hill, attention should be first paid to the leather. If this has been recently treated with paraffin oil, it may be that the surface is too greasy. In this case a little Fullers' earth, or else road dust, should be sprinkled on the leather while the clutch is disengaged. As well as this, it may be found necessary to increase the spring pressure by screwing up the nut N a couple of turns. The pressure should not be increased beyond what is necessary, otherwise the clutch pedal will be hard to operate. When the clutch leather has worn to such an extent that the

cone will not go into the flywheel any further, the clutch will slip, and increasing the spring pressure will probably not effect any improvement. A temporary repair can be effected by inserting thin wedges between the leather and the aluminium cone, the clutch pedal being pushed forward while this is done. In addition, the spring pressure should be considerably increased. When the clutch slips, the pedal should be examined to see if it is fouling the footboard.

#### UNIVERSAL COUPLING.

To allow for any slight movement of the frame members on rough roads, a flexible coupling is placed between the clutch and the gearbox. This prevents any undue wear on the engine and gearbox bearings, and, at the same time, it enables the clutch to be easily removed if this is necessary at any time.

The construction of the coupling is very simple. Both the short shaft B to which the clutch is attached and the gear shaft T end with a taper on which is keyed a trunnion piece—as shown at U and V (page 35). These trunnion pieces carry steel blocks W W which in turn fit in grooves in the sleeves X and Z. Spring washers are fitted beneath the blocks to prevent any rattle. The blocks can rock both on the trunnions and in the grooves of the sleeves so that the coupling is quite flexible.

To remove the coupling it is only necessary to loosen the bolts which connect the sleeves X and Z to the short connecting shaft Y.

The two sleeves should be filled with grease through the brass plugs once every month.



#### GEAR BOX.

The gear box is of the usual sliding gear type, but it is unique in the method of suspension, and also in the extreme shortness of the shafts—a matter of great importance as regards quietness and easy gear changing.

As shown in the illustration, the drive is taken from the clutch coupling V to the main shaft A, which is supported by ball bearings at B and B'. On the shaft A are two sliding gears C and D, which can be moved along the shaft by means of the forks E1 and E2. These forks are, in turn, actuated by the sliding shafts F1 and F2, which are controlled by the change speed lever. There is also a secondary shaft G, supported in ball bearings H H', and this drives the gears J, K, and L, which, however, do not slide along the shaft. The third

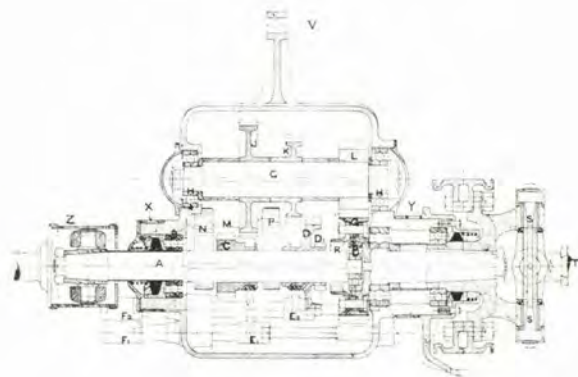

GEAR BOX ARRANGEMENT.

shaft M is the reverse shaft, and this has two gears, N being fixed and P free to slide when actuated by the lower portion of the fork E1. The method of operation is simple. The gears are shown in neutral position. When the change speed lever is moved into first speed position, gear C is moved into mesh with gear J, so that the drive is transmitted from the engine, through the gears C, J, L and Q to the propellor shaft. When the lever is in second speed position the gears D and K are brought into engagement, so that the drive is transmitted through D and K and back through L and Q to the propellor shaft. For top speed the gear D is moved to the right, so that the small gear D<sub>1</sub> meshes with the internal gear R. In this way the drive is transmitted directly from the engine to the propellor shaft without any gears being in operation. To obtain the reverse, gear C is brought into mesh with gear N on the reverse

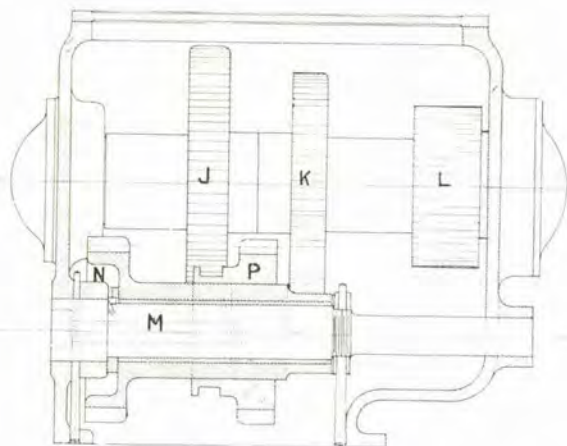

ARRANGEMENT OF REVERSE GEARS.



shaft, and at the same time the other reverse gear P is meshed with gear J. In this way the drive is transmitted from C to N, from P to J, and from L to Q, thus driving the propellor shaft in the reverse direction.

The method of suspension of the gear box is a special Daimler feature. In front and at rear, at X and Y, the gear box is machined so as to form trunnions by which the case is carried in hangers attached to the main cross tubes of the frame. A third support is given by connecting the arm V of the gear case to the front by means of short links. This construction provides a three-point suspension, which ensures that no strain shall come on the gear box and shafts through frame distortion on rough roads.

From the gear box the power is transmitted to the rear axle by means of the propellor shaft, which is provided with flexible joints at each end. These joints must occasionally be packed with grease through the plugs provided.

#### REAR AXLE.

The rear axle fitted to the 1911 cars is of the worm-driven type. At the front portion of the casing there is a filling arm, and every month oil should be poured in till it is level with the top of the arm.

## STEERING GEAR.

The steering gear on all Daimler cars is the irreversible "worm and segment" type. This arrangement gives excellent control with a minimum of effort on the part of the driver and its construction prevents any vibration or shocks from reaching the steering wheel.

The illustration shows a section of the steering box and the lower portion of the steering column. This latter is shown to consist of three concentric tubes and a central rod; in reality, however, there is another tube on the outside, which acts as a cover, and to which the stay from the dashboard is attached. Of the tubes shown in the drawing, the outer tube is attached to the steering wheel at the upper end, and at the lower end it is keyed on to a hardened steel worm wheel shown at B. The wheel engages with the steel segment C, to which the steering arm D is bolted. Hence a movement of

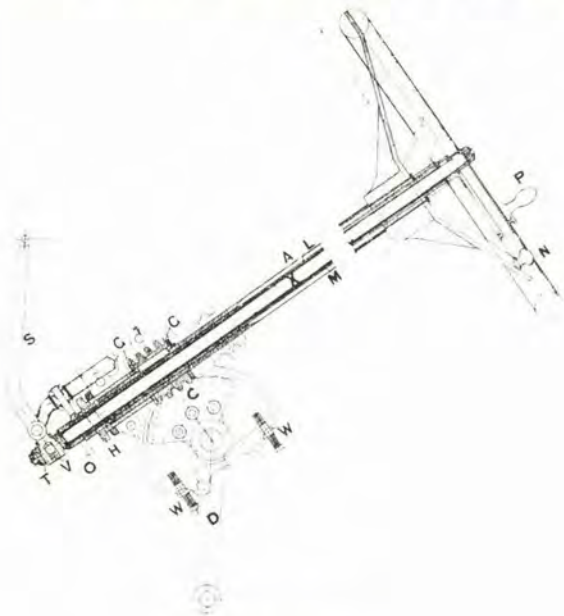

STEERING GEAR.



the steering wheel is directly transmitted to the steering arm, and this in turn operates the front wheels by the connecting rod and the steering arms attached to the front axle pivots. In the steering box the thrust of the worm wheel is taken by the hardened steel washers G G. The lower of these washers can be adjusted by the long nut H, so that any play which may occur in the steering after continued use can be easily taken up.

The tube L within the steering tube serves as a bearing for both ends of the control levers. The throttle tube M is keyed at the upper end to the lever N and at the lower end to the lever O, which is connected by a rod to the throttle lever of the carburettor.

The central rod X transmits the movement of the ignition lever P on the steering wheel to the lever S below by means of the worm V and nut T. This lever S is connected to the magneto and also to the low tension distributor (when fitted).

The set screws S and S in the lower part of the steering box are used to equalise the "lock" or amount of turn of the front wheels in the two extreme positions of the steering wheel. These screws, however, should not be touched after the car has been despatched from the Works.

The steering arms and pivots require regular lubrication (see page 55).



## WHEELS.

The principle of the detachable wheel is probably well known to all motorists. These wheels are fitted to the new Daimler cars as standard, and, unless specially ordered otherwise, wheels of the wire type are supplied. The special advantages of the wire wheels are greater strength, considerable saving in weight, and consequent increase in the life of the tyres. Whether the detachable wheels are of wire or of wood, however, the principle of action remains the same. There is an inner hub which is fixed permanently in position on the front axle, or the rear axle casing, in exactly the same manner as the hub of a fixed wheel. To this hub are attached all fittings, such as the speedometer ring and the brake drums, so that all these parts are kept permanently in place. The wheel itself is built up in the ordinary way on a hollow hub, this hub being made to fit accurately on the inner hub and having grooves in it to fit the projecting keys which are provided on the inner hub for the purpose of transmitting the drive to the wheel. To hold the outer hub in place, a lock nut is provided which is screwed up on a thread machined on the extremity of the inner hub. A spring locking device prevents the nut becoming loose, and, in addition to this, a hand-operated bolt is fitted to provide still greater security.

When the nut is in position, the wheel and the inner hub are locked solidly together, so that the whole arrangement acts in exactly the same manner as a wheel of the ordinary fixed type.

To remove the wheel at any time, it is necessary first to jack up the axle, and then to unscrew the locking cap by means of the special spanner provided. Before the spanner can be fitted to the lock nut, the hand-operated bolt must be swung round into the shallow depression in the lock nut so as to keep it out of the way of the spanner; until this is done it is impossible to get the spanner on. The notches in the lock nut by which



the spanner turns it round are wide so as to allow a certain amount of angular movement of the spanner; consequently, as it is turned in the direction to undo the wheel (this is marked by an arrow on the spanner), the first effect is that the plate on the spanner throws the pawl out of engagement with its ratchet, and so permits the lock-nut to turn round. In fitting the new wheel, the hand-operated bolt must be again in the same position so that the spanner can fit on, but the spanner will be turned the opposite way, thus allowing the pawl to shoot up, disclosing the word "SAFE." This pawl is of the one-way type, and clatters past the ratchet as the wheel is tightened up. The wheel should be tightened up as much as possible, and, if the pawl engages

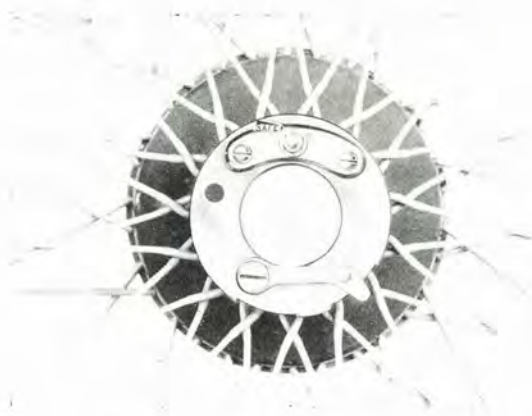

WHEEL SECURE IN POSITION.

with the ratchet, the word "SAFE" will be completely disclosed as in the illustration. The spanner may then be removed and the hand-operated bolt pulled out of the shallow depression and swung round to its original position, where it will prevent any movement in either direction. The plate of the bolt should lie quite flat against the lock nut. If it does not, it is a sure sign that the bolt is not engaging the ratchet, which it cannot do unless the automatic pawl is also engaging its ratchet. Hence this hand-operated bolt forms a useful index when working on the wheel in the dark.



SPANNER IN POSITION FOR REMOVING WHEEL.



## WHEEL HUBS.

The wheels should be removed from the hubs every month or so, and the insides carefully cleaned from dirt, and afterwards oiled before being replaced. It is also advisable to remove the hubs themselves after about six months, or 5,000 miles running.

When the hubs have been removed, they should be carefully cleaned from dirt or rust which may have been caused by water leaking in. All the parts should be well greased and the bearings packed with grease before the hubs are replaced.

Care must always be taken to replace the felt washers, for these are necessary in order to keep the grease from reaching the brakes and also to prevent water and mud from entering the bearings. Similarly, locking arrangements in the shape of split pins, wire rings, or grub screws, must on no account be omitted when the parts are refitted together. All nuts must be well tightened up.

As there are some differences in the construction of the hubs, the various types are referred to in detail.

### FRONT HUBS.

To remove the front hubs, take off the dust cap, withdraw the split pin and unscrew the nut on the end of the axle. The hub shell can then be drawn straight off, assisted, if necessary, by a few taps on the back with a wooden mallet.

### REAR HUBS—38 H.P.

After jacking up the axle and removing the wheel, unscrew the axle cap A. Then unscrew the set screws B and remove the screwed washer C, so that the driving shaft D can be withdrawn. When the locking piece F and nut E have been removed, the hub and ballraces can be drawn off the axle casing G.

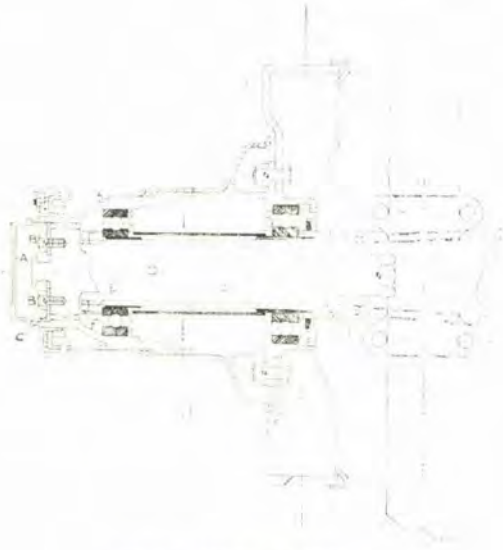

REAR HUB—38 H.P.

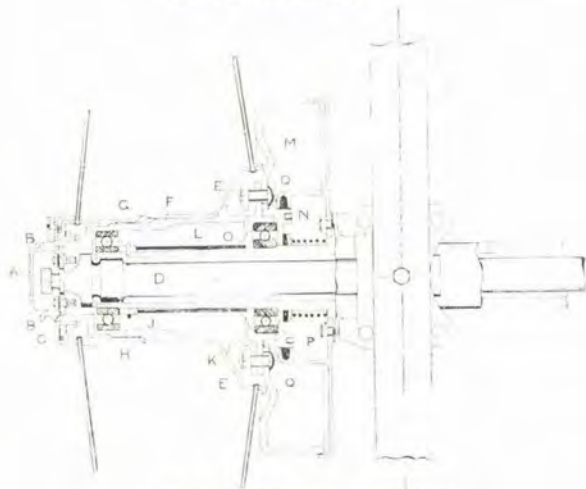

REAR HUB—23 and 25 H.P.



## REAR HUBS. —23 and 25 h.p.

49

After removing the wheel and unscrewing the axle cap A, remove the nuts B and washer C and withdraw the driving shaft D. The six nuts E E must then be unscrewed, so that the sleeve F and ballrace G can be withdrawn. After removing the wire locking ring H and nut J, also the distance piece L and washer O, the remaining parts of the hub K, L, M, N will be accessible, and these can be drawn off the axle casing together. To separate the parts, remove the small grub screw P, unscrew the cap N and withdraw the six bolts Q Q.

When the hubs are taken off for the periodical cleaning and greasing, it is not necessary to separate the parts K, L, M, N.

## REAR HUBS. —15 h.p.

The hub is supported on a large ball bearing C on the end of the axle casing and it is also keyed on the driving shaft D. To draw it off the latter, remove the hub cap A, the split pin, and the nut B on the end of the driving shaft. Then screw up in place of the hub cap "A," the withdrawal cap which is supplied with the accessories, taking care that the threaded portion of the cap is screwed right into the hub to ensure a good hold on same, and that the set screw in the end of the cap extends sufficiently far to permit this being done.

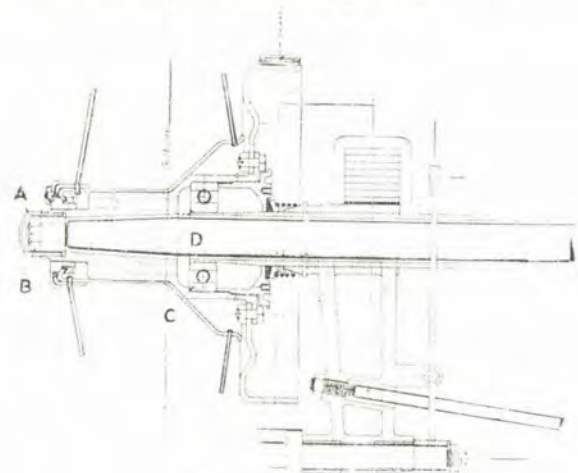

REAR HUB—15 H.P.

## BRAKES.

All the models have a double system of brakes—a pair of contracting brakes at the rear wheels and a contracting band brake on a drum on the propellor shaft.

The rear wheel brakes are shown in the accompanying photo.



REAR BRAKE.

To adjust these brakes, loosen the locking nut B and tighten up the set screw A. Take care to adjust both brakes equally.

## PROPELLOR SHAFT BRAKE.

The construction of this brake is shown in the illustration. The drum A is bolted to the gear box shaft and revolves with the propellor shaft. The band B is connected at one end to the pin C and the other to the eye piece D, the latter being connected by the rod E to the second pin F. Pins C and F are connected to the shaft G, which is actuated by the brake lever. When the lever is actuated, the shaft G is turned clockwise,



and the two ends of the band are drawn equally into contact with the drum, being thrown apart again by



PROPELLOR SHAFT BRAKE.

spring H when the pressure is released. The arms K, K, are provided with set screws to keep the band evenly in place all round the drum.

To adjust the brake, the rod E is turned by means of a brass nut, situated beneath the side frame member on the driver's side.

## SPRINGS.

Important modifications have been introduced in the arrangement of both the front and rear springs on the new Daimler cars. The front springs are fitted with a special swivel shackle at their rear ends. The construction of this shackle will be apparent from the illustration. Its great advantage is that it prevents any binding action being set up in the springs when the frame is distorted slightly—such as, for example, when the car is travelling with heavy load over a rough road. The new shackle

greatly adds to the smoothness of action of the springs, as any user will readily testify.

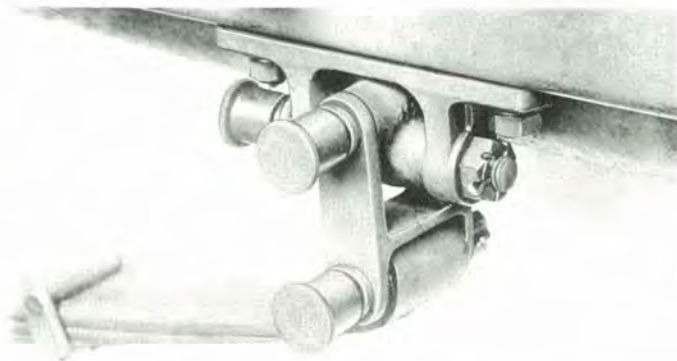

SWIVEL SHACKLE ON FRONT SPRING.

This shackle must be regularly lubricated (by means of the screw-down grease caps provided) if the full advantages are to be obtained.

Likewise, the rear springing has been improved to such an extent that the comfortable riding of the Daimler cars is almost as remarkable a feature as the flexibility and power of the engine. The main improvement has been the addition of the supplementary spiral springs shown in the accompanying photo. These spiral springs absorb all the small road shocks and also serve to damp the oscillation of the main springs when the car is travelling over rough roads.



The joints and links of these springs should all be lubricated daily by screwing up the grease caps.



SUPPLEMENTARY SPRINGS AT REAR.

### SPRING CLIPS.

The spring clips which secure the springs to the axle should receive attention occasionally. The springs are gripped by these clips through a leather washer, and while this leather helps to secure the springs tightly, it eventually becomes compressed by the road shocks and the clips may finally become loose. Hence, the clips should be examined monthly and the nuts tightened if found necessary.

### SILENCER.

The silencer ends should be taken off occasionally by removing the bolts which hold them to the casing, and the deposit of burnt lubricating oil should be cleared out from the tubes. This operation should only be necessary every 5,000 miles or so, but there will usually be an improvement in the running when it has been done.

## SECTION II.

# Lubrication.

As stated at the commencement of the book, efficient and regular lubrication of all moving parts is essential for the proper maintenance of the car. The driver should be instructed to give his full attention to this matter and not to neglect any part, however unimportant it may seem. The improvement due to this attention to lubrication may not be so marked when the car is new, but, after it has been on the road for a year or more, the absence of any rattle or noise and the continued smoothness of the springing will amply repay the time that has been spent in this way.

It is best for the car to be always lubricated with the same kind of oil and grease.

The Daimler Co. supply these articles in the best quality, and strongly recommend their use on all Daimler cars.

- " Daimler " Cylinder Oil .. for engine lubrication.
- " Daimler " Gear Grease .. for gear box and grease lubricators.
- " Daimler " Thick Oil .. for rear axle.

### PRICES.

" DAIMLER " CYLINDER OIL—			
1 gallon tins ..	..	4/6	
5 gallon drums ..	..	20/-	
" DAIMLER " GEAR GREASE—			
1 lb. ..	..	-/6	
56 lbs. ..	..	22/6	
" DAIMLER " THICK OIL—			
1 gallon tins ..	..	3/-	
5 gallons drums ..	..	12/6	

Allowance for drums, if returned carriage paid, 5/-.



### FILLING THE PETROL TANK.

All petrol poured into the tank must be strained through the tundish provided, in order to prevent any water passing through.

### FILLING THE RADIATOR.

Soft water should be used where possible, and no dirt should be permitted to enter the radiator. If the radiator is being filled up after being empty, the tap at the bottom of the pump must be kept open till the water pours out in a steady stream. In cold weather, if there is any danger of the temperature falling to freezing point, all the water must be drained out of the radiator and the cylinder heads before the car is left for the night.

### DAILY ATTENTION.

Apart from the washing and cleaning of the car which is referred to later on page 71, care should be taken every morning before starting out on the road to see that there is sufficient petrol in the tank and water in the radiator, and that the oil in the engine is up to the necessary level.

The steering pins should then be lubricated at the places shown on the accompanying illustration by putting a few drops of oil in the lubricators marked 4, 5, 6, and 7 (see next page), and by giving the grease caps 2 and 3 a couple of turns. The grease cap for the clutch bearing (marked No. 8 on p. 59) should also be given two turns, and the grease caps on the pins of all the springs should be given a turn.

The tyres must be inspected and, if found necessary, these must be inflated to the correct pressure. The security bolts and valve nuts must also be tightened up.

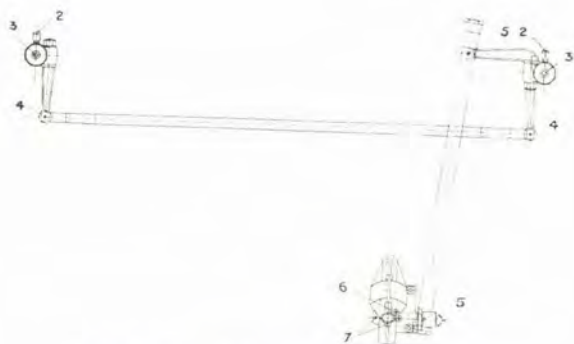

LUBRICATORS ON STEERING GEAR.

## EVERY 250 MILES, OR WEEKLY.

After this period it is advisable to attend to all the lubricators on the car, although, of course, if any or all of the operations enumerated below are performed more frequently, so much the better for the car.

If the following instructions are carried out in a methodical way, the time taken will be considerably reduced and it will be found that, after the first or second time, the assistance of this book will not be required. To perform the various operations, the driver should start on the right-hand or carburettor side of the engine and then proceed round the front of the car to the left side of the engine. Next, attend to those parts which lie under the front and rear floor boards respectively, finally passing round the rear of the car till the change speed levers are reached. In this way a complete circuit of the car will be made.

The numbers in the illustrations correspond with numbers given for the various operations under each section.

### I. Right side of engine—

- (1.) Put oil in the two lubricators on the steering box.
- (2.) Put one drop of oil on each of the six joints of the ignition levers.
- (3.) Put one drop of oil on the four joints of the throttle levers.
- (4) and (5.) Lubricate the steering pins and spring shackles as described in "Daily Operations" on page 55.

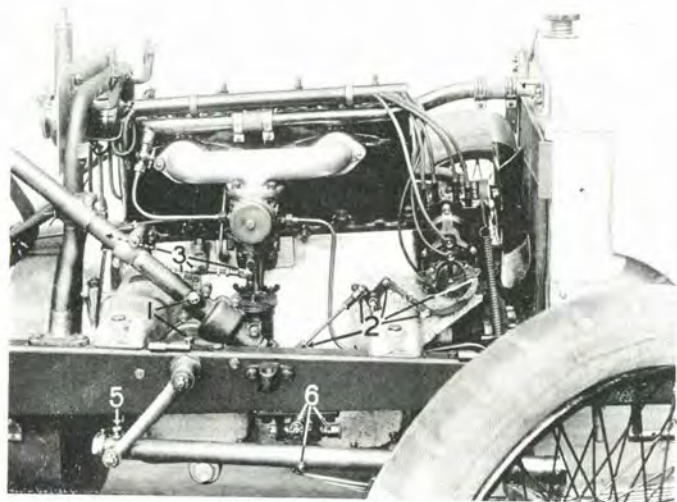

RIGHT SIDE OF ENGINE.

## II. Left side of engine—

(1.) Oil the starting handle shaft where it passes through bracket and where it enters the end of the crankshaft. Move the shaft backwards and forwards while doing this.

(2.) Give a couple of turns to the two greasers on the fan bracket and shaft.

(3.) Screw up the spring shackle greasers.

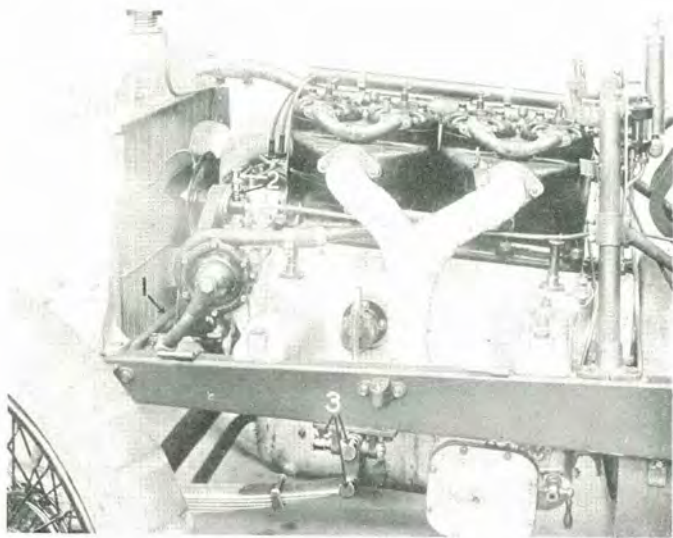

LEFT SIDE OF ENGINE.

## III. Remove the front floor boards—

(1.) Put oil in the four lubricators on the pedal shaft.

(2.) Oil the pin at the end of the clutch spring rod and brake rod.

(3.) Oil the pins on which the three pedal plates rock.

(4.) Oil the moving part of the change speed tube while rocking the change speed lever sideways.

(5.) Oil the control rods at the five points shown.

(6.) Oil the two brake rod pins.

(7.) Screw down the two greasers on the change speed shaft a couple of turns.

(8.) Fill up the grease lubricator on the clutch ball thrust bearing.



FRONT FLOOR BOARDS REMOVED (1).



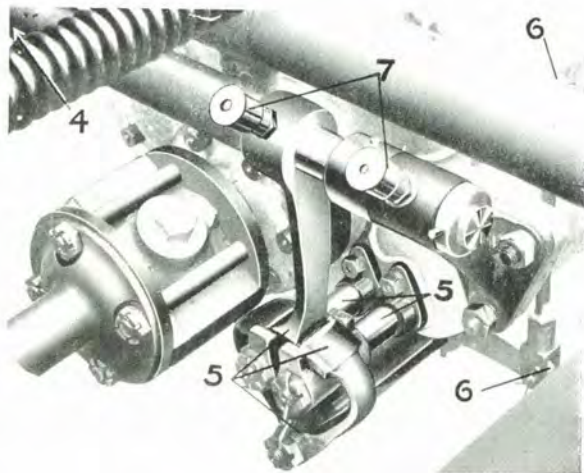

FRONT FLOOR BOARDS REMOVED (2).



REAR FLOOR BOARDS REMOVED (1).

## IV. Remove the rear floor boards—

(1.) Oil the four joint pins of the gear box brake rods.

(2.) Unscrew each of the four universal joint greasers, after having lifted the wire locking rings out of place by means of a screwdriver or knife, and refill with grease. Take care to replace the wire rings afterwards.

(3.) Oil the five pins on the foot brake rods.



REAR FLOOR BOARDS REMOVED (2).

## V. Proceeding round the rear of the car—

(1.) Screw down the two greasers (marked 4 and 5 in last photo).

(2.) Screw down the two greasers on rear of both springs.

(3.) Screw down the two greasers on brake pin on both sides of the car.

(4.) Repeat No. 1 above on right-hand side of car.



SHOWING ADJUSTMENT AND LUBRICATION OF  
REAR BRAKES



## VI. On reaching the driver's seat—

(1.) Oil the change speed gear at the five points marked.

(2.) Screw up the greaser shown.

(3.) Pour a few drops of oil down the hole in the nut on top of the steering wheel.

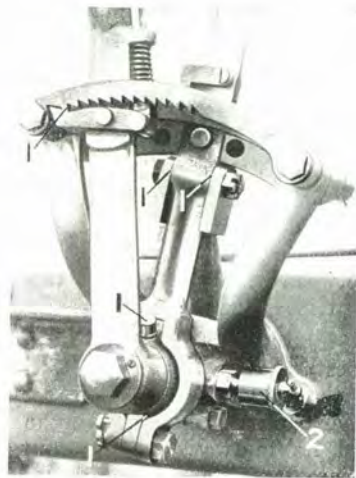

LUBRICATION OF CONTROL LEVERS.

Every fortnight, a few drops of oil should be poured into the lubricators which will be found at both ends of the magneto; also the plug at the bottom of the petrol tank should be removed and about a pint of petrol drawn off. Any water which may have entered the tank will be removed in this way.

It is also advisable every week to apply the spanner to the detachable wheels and to screw the cap up further, if possible, by tapping with a hammer. This will prevent any chance of the wheels being run loose for a long period.

## EVERY 2,000 MILES, OR AFTER TWO MONTHS—

At the end of this period, certain further operations are necessary. A day will be well spent on this work:

(1.) The accumulators should be taken out and properly charged (see page 24).

(2.) Remove the plugs in the two universal joint sleeves between the clutch and gearbox, and refill with grease. Do the same with the joint at the rear end of the propellor shaft.

(3.) Lubricate the leaves of the springs by removing the small spring clips and jacking up the frame till the weight is just taken off the wheels. The leaves will then separate slightly, and oil or thin grease can be smeared between them with the aid of a flat knife. The spring clips must afterwards be replaced and tightened.

(4.) Test the adjustment of the brakes and tighten up the pull-on rods if necessary. The brake should be hard on the drum before the lever or pedal has reached its midway position, but at the same time the drum must be quite free when the brake is off. This is best tested by jacking up the rear wheels and seeing that they revolve quite freely.

(5.) Remove the detachable wheels and clean both the inner and the outer hubs from any dirt or rust which may be present. Thoroughly grease these parts before replacing the wheels.

(6.) Examine the magneto contact breaker; clean and adjust if necessary (see page 27). Pour a few drops of oil into each of the magneto lubricators.

(7.) Examine the trembler coil; do not adjust this unless the engine is not running satisfactorily on the accumulator ignition (see page 24); also examine all the wires and see that the terminal nuts are tight.



(8.) Replace the accumulators and arrange the connections the opposite way to their previous position, *i.e.*, if the two red wires have previously been connected to the red accumulator terminals, now connect them to the black terminals and connect the black wires to the red terminals. This will cause the current to circulate in the reverse direction and so will lessen the wear on the trembler points.

## EVERY 5,000 MILES, OR HALF YEARLY.

(1.) If the engine has shown any signs of knocking or pre-ignition, **BUT NOT OTHERWISE**, remove the cylinder heads (see page 13) and clean the deposit of charred oil from the heads and pistons. Keep the different heads and rings separate so that there may be no possibility of a mistake when replacing.

(2.) Remove the drain plug at the base of the engine and let all the old oil drain out. Replace the plug and pour about half a gallon of paraffin through the filler. Run the engine for a moment or two, and then drain out the paraffin. Afterwards refill to the proper level with clean oil, and run the engine for a minute or two, racing it occasionally for a few moments to make sure that the clean oil reaches all the parts.

(3.) Before putting the fresh oil into the engine, remove the side covers of the base chamber and clean the gauze filter from any dirt which it may have collected from the oil.

(4.) Remove the cover plate at the base of the gearbox and remove all the old grease, washing any dirt out with a little paraffin. Then replace the bottom cover plate and half fill the gearbox with new grease.

(5.) Remove all the old oil from the rear axle casing, washing out any dirt that may be present with a little paraffin. Then pour about a gallon of thick gear oil into the casing. For the 22 h.p. about two-thirds of a gallon will be sufficient, while half gallon will be ample for the 15 h.p. axle.

(6.) Drain all the water out of the radiator and refill with clean soft water. If the system is likely to be incrustated with deposit (usual when the car is used in a limestone district) the radiator should be filled with a solution of washing soda and the car run for a day in this way. Afterwards the soda water must be washed out and the radiator refilled with clean soft water.

(7.) Detach the petrol filter and clean this thoroughly. While the filter is detached, remove the union nut at the bottom of the float chamber and allow all the petrol to run out, together with any water or dirt which may possibly have passed the filter. When replacing make sure that all the joints are petrol tight.

(8.) Take off the detachable wheels for their monthly greasing and also remove the hubs (see page 47). While the hubs are off, examine the brake shoes and pins. If the former show much sign of wear they must be relined, while the latter must be well cleaned and lubricated. When replacing, make certain that all parts are securely locked in position.

(9.) Test all the joints of the steering gear for looseness and tighten up if necessary. The joint pins, however, must be all quite free.

(10.) Remove the plug at the bottom of the petrol tank and drain all the petrol out, rocking the car to enable the last portions to flow out. Replace the plug and carefully strain the petrol into the tank.

(11.) Get underneath the car and carefully examine all parts for loose nuts. If any are found, tighten up, and remember to examine the same places after a short time to see if they have remained tight.

(12.) Remember that in nothing so much as in motor car work does the old adage about the "stitch in time" apply, and that an extra hour spent in adjustments in the motor house may save much trouble on the road.



The length of time that a car will run before it has to visit a workshop for replacements or special adjustments varies considerably according to the amount of attention and the care in lubrication which has been paid. In the average case it is advisable to have the car examined after two years' use, or 20,000 miles running.

The Daimler Co. have an extensive Repair Department at the Coventry Works and at the Depôts listed on the title page. It is recommended that the car should be sent to one of these places to receive the careful attention of skilled workmen, who have been trained in the construction and repair of Daimler cars.



## SECTION III.

## Driving Notes.

It is presumed that the reader of these notes has at least an elementary knowledge of driving. If not, such knowledge can be more easily acquired by a few practical lessons from an instructor than by reading many pages of written directions. The following hints will serve to show a person who can already drive how to obtain best results from his Daimler car.

## STARTING THE ENGINE.

If the gauge shows that there is no pressure in the petrol tank, close the tap on the pressure pump and work the latter till the gauge registers 2 lbs. pressure. Turn on the petrol tap, switch on the accumulator ignition, give the starting handle two or three turns, and the engine should start. The throttle lever should only be advanced about 1 inch from the "closed" position and the ignition lever should be similarly placed. When the engine has started, the magneto ignition should be switched on instead of the accumulator. If it is desired to start on the magneto, the ignition lever on the wheel should be fully advanced.

## STARTING THE CAR.

Usually the car can be started on second speed, except when on a steep hill. The engine should not be raced excessively at starting, for it will be found that the clutch may be let right in when the engine is running comparatively slowly. As soon as the car has reached its normal speed, top gear should be engaged, and, after this, it will be found that the full variation in speed, whether on the level or up hill, can be obtained simply by opening or closing the throttle.



## RUNNING THE CAR.

The best rule to follow with regard to the control levers is to keep the throttle closed as much as possible for the speed desired, to supply as much extra air as the engine will take (this is done by depressing the air pedal), and to advance the ignition lever. For very slow running it is best to cut off the extra air supply altogether. For very fast running, full throttle, full air, and full ignition advance must be used. When climbing hills at fast speed, it will usually be found best to pull the throttle lever back three or four notches, and also to retard the ignition lever if the engine begins to "knock."

## GEAR CHANGING.

When changing up from first speed to second, or from second to top, the throttle lever should be retarded, the clutch pedal depressed about half way, and the change speed lever moved quickly over to the correct position.

When changing down, the throttle lever should be left half-way advanced, the clutch slightly depressed, and the gear lever moved into neutral position. The clutch should then be let in for a moment, and immediately afterwards depressed, the gear lever being slipped into position simultaneously with the last clutch movement.

Only when engaging a gear with the car at rest should the clutch pedal be pushed right forward.

## BRAKES.

The foot brakes should be used normally, the hand brake being reserved for emergencies. Recourse should always be had to the engine as a brake by fully closing the throttle. The clutch should not be disengaged until the car is being brought to a standstill.

## HINTS TO DRIVERS.

(1.) The maxim for the careful driver is "Don't take any risks." If this is acted upon, there will not be much chance of accidents.

(2.) Keep a careful look out at all cross roads and when entering a main road. It is at these places that most of the serious accidents occur.

(3.) Remember that the silence of the car makes the speed seem much less than it actually is. This fact should be carefully kept in mind and allowances made accordingly.

(4.) Drive slowly round corners if you wish your tyres to last long, and for the same reason avoid sudden application of the brakes, except in case of emergency.

(5.) Always show consideration for other road users, whether pedestrians, cyclists, or horse drivers. This consideration consists in (a) not trying to pass too closely, and (b) slowing down for a few moments when passing on a dusty or muddy day.

(6.) Drive slowly on greasy surfaces and avoid sudden acceleration or application of the brakes. Use the engine as a brake, and avoid use of the clutch as much as possible.

(7.) If a short patch of unrolled stone is encountered, the best way to proceed is to approach it with just sufficient speed to enable the car to roll over the patch with the clutch disengaged. This is better for the tyres than driving the car slowly over the patch. Above all, the car should not be stopped when on the stones, for the effort of starting might perhaps damage the rear tyres.



## WASHING THE CAR.

If the well finished appearance of the car is to be maintained, careful washing is essential. It is advisable to wash the car frequently, particularly when the car is new, and the washing must invariably take place at the end of the day's run, before the mud has dried on the varnish. Cold water must be used and nothing else, for the addition of petrol, paraffin, or anything of this nature will cause the varnish to become dull quickly. The water should be sprayed on with a hose, but the pressure must be reduced considerably, otherwise the particles of mud will scratch the surface. When every atom of mud and dust has been washed off, the body may be wiped down with a wet clean sponge and afterwards dried with a clean chamois leather.

Excess of water should not be used on the steering arms or pivots, or else the lubricating oil may be washed out.

If the leather upholstery is dirty, it may be washed with soap and water, and afterwards polished, if necessary, with leather reviver.

The cushions should always be taken out of the car and dried after a run on a wet day.

A French-polished surface should not be washed with soap and water; a drop of linseed oil will quickly restore its brilliancy.

## HINTS ON THE TREATMENT OF BODIES.

(1.) Never bang a door to shut it; a properly fitted door shuts easily with a gentle slam. Continued banging will loose the hinges and so set up a rattle, while the paint is apt to chip and fall.

(2.) If a door rattles, the hinges should have the attention of a coachbuilder. The adjustment is simple and effective, whereas the common method of nailing a piece of leather along the door post will make matters much worse in the end.

(3.) The car should not be left in the sun on a hot day unless this is unavoidable. The heat may cause the varnish to blister.

(4.) The car must never be pushed along by placing the hands against the panels, or by pulling on the door handles or similar fittings. The correct method is to push the back of the frame or, easier still, to turn the wheels by pulling on the tyres.

(5.) When lowering the body, after this has been raised at any time for inspection of the gear-box, care must be taken that the canopy (if fitted) joins the wind screen connections properly, and, also, that the studs at the front end of the base of the body enter the holes in the supporting bracket. Before taking out the handle, after the body has been lowered, turn same *slightly* in the reverse direction in order to take the strain off the body raising screw. Then tighten up the nuts on the holding-down studs.

### TO LOWER A LANDAULETTE HOOD.

(1.) Drop the inside curtain and fix it along the back pillar with the window.

(2.) Undo the two fasteners on top of the hood.

(3.) Raise the folding part of the roof straight up.

(4.) Fold the near-side joint just enough to pass the centre, and do the same on the other side. Do not attempt to fold the hood down first.

(5.) From the back of the car pull the hood gently down.

(6.) When the hood is folded, the back light should not hang on the back panel but must be folded inside, resting on the back squab.



### HINTS ON THE CARE OF TYRES.

(1.) See that the tyres are inflated up to the correct pressure, and verify this by using a pressure gauge occasionally. The table given below shows the correct pressure for the various sizes.

(2.) The wing nuts and valve nut must be tightened up occasionally to prevent water getting inside the tyre.

(3.) The small dust cap must always be fitted over the valve to ensure an airtight joint, and the rubber disc inside it must never be omitted.

(4.) If the air slowly leaks out of a tube and no puncture is apparent, the hexagon nut which secures the valve to the tube may require tightening.

(5.) The wheels should not be washed if the tyres are deflated, otherwise water and grit will penetrate to the inside of the tyre.

(6.) Tyres which appear to be in good condition should be taken off and examined at least every 5,000 miles. If the rims are rusted inside, they must be cleaned and painted. The cover must be well chalked before it is replaced.

(7.) Great care must be taken to prevent oil coming in contact with the tyres, for nothing is more injurious to the rubber.

(8.) All covers carried on the car should be well protected by means of a waterproof wrapper and all tubes should be carried in a rubber bag containing a handful of chalk.

### TYRE PRESSURE TABLE.

	FRONT	BACK
90 m/m	70 lbs.	80 lbs.
105 m/m	75 lbs.	85 lbs.
120 m/m	80 lbs.	90 lbs.
135 m/m	80 lbs.	90 lbs.

## SECTION IV.

## Troubles and their Location.

As was stated at the commencement of this book, troubles with the engine or other parts of the car are not matters of frequent occurrence; on the contrary, a whole season may pass without recourse ever having to be made to the directions given below.

When, however, any unusual symptom is apparent, either by some noise or by a falling off in the power of the engine, the circumstances should be noted, and, by reference to the following table, the reason can be at once determined.

All possible causes of the given trouble are stated, but a small amount of general experience should enable the operator to choose the one appropriate to his case.

### TROUBLE. ENGINE WILL NOT START—

- CAUSE. (1.) Carburation.  
(2.) Ignition.

REMEDY. (1.) Flood carburettor to make sure that the petrol is flowing properly. If mixture "weak" (probable in cold weather or when first starting), inject a little petrol in the cocks on the inlet pipes. If mixture "rich" (possible in hot weather or when the engine is hot after a run), fix air pedal in open position, also open cocks on inlet pipes if necessary.

- (2.) Examine the sparking plugs for water or oil on the points. Examine accumulator and switch; see if wiring terminals disconnected or loose; see if trembler blade stuck.

### TROUBLE. ENGINE STARTS BUT WILL NOT CONTINUE TO RUN—

- CAUSE. (1.) Accumulator run down.  
(2.) Petrol not flowing freely to carburettor.

- REMEDY. (1.) Try the other accumulator or switch on to magneto.  
(2.) See if tap turned on fully; see if gauge shows correct pressure at tank; see if dirt in float chamber or pipes.

### TROUBLE. ENGINE WILL NOT RUN FAST—

- CAUSE. (1.) Accumulator weak.  
(2.) Trembler requires adjustment.  
(3.) Ignition retarded.  
(4.) Magneto requires adjustment.  
(5.) Silencer choked.

- REMEDY. (1.) Recharge the accumulator.  
(2.) Adjust trembler (see page 24).  
(3.) See if ignition lever works the distributor correctly.  
(4.) Adjust contact breaker (see page 27).  
(5.) Remove silencer and clean the tubes.

### TROUBLE. ENGINE STOPS SUDDENLY—

- CAUSE. Ignition failure.

- REMEDY. Examine the wiring from magneto or accumulator to the switch and from the accumulator to the frame.



**TROUBLE. ENGINE WILL NOT STOP WHEN SWITCHED OFF—**

- CAUSE.** (1.) If firing is regular, switch defective or wire disconnected.  
 (2.) If firing is irregular, pre-ignition.
- REMEDY.** (1.) To stop the engine, shut the throttle or turn off the petrol; then examine switch and wiring.  
 (2.) Clean plugs; if necessary, clean burnt oil from cylinders by removing the heads.

**TROUBLE. ENGINE MISFIRES REGULARLY IN ONE CYLINDER—\***

- CAUSE.** Plug defective; wire loose or short circuited; asbestos washer on inlet pipe broken (unlikely).
- REMEDY.** Change plug; examine wiring; fit new washer.

**TROUBLE. ENGINE MISFIRES IRREGULARLY—**

- CAUSE.** (1.) Ignition.  
 (2.) Carburettor.
- REMEDY.** (1.) Examine contact breaker, distributor, wiring, switch, plugs, accumulator.  
 (2.) See if there is any dirt or water in the float or jet chamber; see that the petrol is flowing properly.

**TROUBLE. ENGINE FIRES IN SILENCER—**

- CAUSE.** Unfired charges passing through the engine.
- REMEDY.** Examine as in last section; particularly see if the plug points are too far apart.

\* For method of locating defective cylinder, see page 80.



**TROUBLE. ENGINE "POPPS" OR FIRES BACK INTO CARBURETTOR—**

- CAUSE.** (1.) Mixture too weak.  
 (2.) Ignition occurring at wrong time.
- REMEDY.** (1.) Examine pressure and fuel supply; see if there is any dirt or water in the carburettor; see if the inlet pipe joints are loose.  
 (2.) Look for short circuits in distributor.

**TROUBLE. ENGINE DOES NOT "PULL" WELL—**

- CAUSE.** (1.) Ignition or carburettor faulty.  
 (2.) Engine short of oil.  
 (3.) Silencer may be choked with burnt oil.  
 (4.) Brakes may be dragging—indicated by the drums becoming hot.  
 (5.) If in winter, the engine may be too cold.
- REMEDY.** (1.) As before.  
 (2.) See if pump working properly, and if there is sufficient oil in base.  
 (3.) Clean out the burnt oil.  
 (4.) Adjust the brakes.  
 (5.) Remove fan belt; replace this when the warm weather comes along.

**TROUBLE. ENGINE OVERHEATS (INDICATED BY WATER BOILING IN RADIATOR)—**

- CAUSE.** (1.) Ignition too much retarded.  
 (2.) Want of water.  
 (3.) Circulation defective.  
 (4.) Fan not working.  
 (5.) Pump not working.  
 (6.) Engine short of oil.

- REMEDY. (1.) Advance ignition lever.  
 (2.) Refill the radiator after the engine has cooled down somewhat.  
 (3.) Clean pipes out with soda (see page 17).  
 (4.) Adjust fan belt.  
 (5.) See if pump-driving cotter is in place.  
 (6.) Put oil in base chamber; pour a little through the taps on the inlet pipe.

TROUBLE. ENGINE MAKES UNUSUAL HISSING NOISE—

CAUSE. Leakage of gas from cylinder or pipes.

REMEDY. See if sparking plug broken; if inlet or exhaust pipes loose; or their washers blown out; see if taps on inlet pipe open.

TROUBLE. ENGINE MAKES KNOCKING NOISE—

CAUSE. (1.) Pre-ignition.  
 (2.) Loose bearings.

REMEDY. (1.) Retard spark. If knock still continues change the plugs one at a time. If necessary, clean burnt oil out of cylinders (see page 13).  
 (2.) This should not occur till after a long period of running (see page 67).

TROUBLE. ENGINE RUNS WELL BUT WILL NOT DRIVE CAR—

CAUSE. Clutch slipping (see page 37).

REMEDY. Increase tension on spring; pour a little petrol on leather; as a last resource apply Fuller's earth or resin to the leather.



TROUBLE. UNUSUAL NOISE IN TRANSMISSION GEAR—

- CAUSE. (1.) If a humming noise, the gearbox or rear axle is probably short of grease or oil, or one of the bearings requires lubrication.  
 (2.) If a tapping or knocking noise, some part loose.

REMEDY. (1.) Attend to the lubrication as described in Section II.

(2.) Locate the source of the trouble by noting its frequency relative to the rate of revolution of the rear wheel, or to that of the propellor shaft (the rate of the latter being approximately three or four times that of the rear wheels). When the source is located, jack up the wheels and examine the parts for undue play or looseness. If the trouble is in the propellor shaft, examine the two universal joints and the gear box brake.

OIL INDICATOR—  
 TO CLEAN GLASS.

Unscrew the brass cap on the top of the indicator and the glass tube can then be withdrawn. To prevent the oil splashing on to the glass, cut down the supply till the oil only drips down slowly. This cutting down of the supply at the gauge does not diminish the supply in the engine itself.

## TO LOCATE A MISFIRING CYLINDER.

If the engine is misfiring regularly in one or more cylinders, the source of trouble may be located by cautiously touching the separate exhaust pipes in turn. Those pipes which lead from the defective cylinders should be cooler than the others. Another method is to short-circuit the plugs of each cylinder in turn, while the engine is running. To do this, a wooden-handled screwdriver should be held so that the metal blade is in contact with the cylinder head and with the terminal of the plug. If the cylinder which is being tested is firing correctly, this short-circuiting of the plug will reduce the speed of the engine. When the misfiring cylinder is reached, no reduction in the engine speed will be noted.

## UNUSUAL NOISES.

On account of the multitude of moving parts on a car, slight squeaks or noises are sometimes set up. Owing to the exceptional silence of running of the Daimler cars, these slight noises are specially noticeable, and hence a few words on their location may be useful. If the squeak is regular in occurrence, it must be caused by some revolving part. By running the engine with the car at rest, it can be determined whether the trouble is in this part or not. If not in the engine, the squeak is probably in the clutch mechanism or in one of the universal joints, or perhaps the brakes are rubbing slightly on their drums. A few minutes with the oil can will put these matters right. If the squeak is intermittent, the springs and spring shackles should be examined and lubricated. When the squeak is specially noticeable on rough roads it is almost certain to be caused by one of these parts.



## Registration and Licensing.

(1.) Every car must be registered with the Council of a County or County Borough. Application should be made to the Clerk of the particular Council with which the owner desires to register his car (not necessarily that of the place where he resides) for a form of registration. This must be returned with the fee of £1 to the Clerk, who will then allot an identifying mark for the car. This mark must be painted on plates to be attached at the front and rear of the car. The figures and letters must be painted white on a black ground, and the minimum height of each figure must be three and a half inches. The rear plate must be illuminated at night.

If the ownership of the car is changed, notice must be given to the registering authority either to cancel the registration or to transfer it to the new owner, who must fill in a form and pay a fee of 5/-. This is most important.

(2.) Before a person may drive a car, he must obtain a driving license from the Council of the Borough or County in which he resides. The fee is 5/-, and the license must be renewed annually at a further cost of 5/-. The driving license must always be carried when its owner is driving the car and must be shown to any police constable on demand. If a license is lost, a duplicate may be obtained for a fee of 1/-.

(3.) A list of the taxes imposed by the Treasury is given on the next page.

(4.) Armorial bearings used on cars are subject to an Inland Revenue tax of £2 2s. 0d. The term "armorial bearings" includes any bearing, crest, or ensign, whether registered at the College of Arms or not. A license is not required when only a Club badge or crest is used.

(5.) Motorists keeping a male servant must take out a Male Servant License annually at a cost of 15/-. The term "male servant" is defined as including a driver or person employed in any capacity involving that duty.



Diameter of cylinders.		CORRESPONDING TAXATION RATING.			
m/m	inches.	6-cyl.	4-cyl.	2-cyl.	1-cyl.
108	4·25	43·4	28·9	14·5	7·23
109	4·29	44·2	29·4	14·7	7·36
110	4·33	45·0	30·0	15·0	7·50
111	4·37	45·8	30·5	15·3	7·63
112	4·41	46·7	31·1	15·6	7·78
113	4·45	47·5	31·7	15·8	7·92
114	4·49	48·4	32·2	16·1	8·06
115	4·53	49·2	32·8	16·4	8·20
116	4·57	50·0	33·4	16·7	8·34
117	4·61	50·9	33·96	16·98	8·49
118	4·65	51·8	34·5	17·3	8·63
119	4·69	52·7	35·1	17·6	8·78
120	4·72	53·6	35·7	17·9	8·93
121	4·76	54·5	36·3	18·2	9·08
122	4·80	55·4	36·9	18·5	9·23
123	4·84	56·3	37·5	18·8	9·38
124	4·88	57·2	38·1	19·1	9·53
125	4·92	58·1	38·8	19·4	9·69
126	4·96	59·0	39·4	19·7	9·84
127	5·00	59·99	39·99	19·99	9·99
128	5·04	60·96	40·6	20·3	10·16
129	5·08	61·9	41·3	20·6	10·32
130	5·12	62·8	41·9	20·9	10·47
131	5·16	63·8	42·6	21·3	10·64
132	5·20	64·8	43·2	21·6	10·80
133	5·24	65·8	43·9	21·9	10·97
134	5·28	66·8	44·5	22·3	11·13
135	5·32	67·8	45·2	22·6	11·30
136	5·36	68·8	45·9	22·9	11·47
137	5·39	69·8	46·6	23·3	11·64
138	5·43	70·9	47·2	23·6	11·81
139	5·47	71·9	47·9	23·96	11·98
140	5·51	72·9	48·6	24·3	12·15
141	5·55	73·9	49·3	24·6	12·32
142	5·59	75·0	50·0	25·0	12·50
143	5·63	76·1	50·7	25·4	12·68
144	5·67	77·1	51·4	25·7	12·85
145	5·71	78·2	52·1	26·1	13·03
146	5·74	79·3	52·8	26·4	13·21
147	5·78	80·4	53·6	26·8	13·40
148	5·82	81·5	54·3	27·2	13·58
149	5·86	82·6	55·0	27·5	13·76
150	5·90	83·7	55·8	27·9	13·95
155	6·10	89·3	59·6	29·8	14·89
160	6·30	95·2	63·5	31·7	15·87
165	6·49	101·3	67·5	33·8	16·88

# TAMPA BAY

## AUTOMOBILE MUSEUM

### Storage of Petrol.



Petrol may only be stored in two gallon tins (unless a license permitting otherwise has been obtained from the local authorities), and these must be kept in a storehouse which must not be used as part of a dwelling or place where persons assemble. Not more than 60 gallons may be kept in a single storehouse, inclusive of the amount in the tank of the car, if it be kept in the same place, while, if a second storehouse is used, this must not be within twenty feet of the first.

If a person keep petrol within twenty feet of any other building or of any timber stack, he must give notice to the local licensing authority, and must allow their officer to inspect the storehouse at any reasonable time. The notice must be renewed in the January of each year. This regulation does not apply when the petrol is only kept in the tank of the car. If petrol is used for cleaning purposes or for the repair of tyres, not more than one gill may be used at any one time.

### Insurance.

We strongly recommend car owners to insure against accidents, for, however careful a driver may be, there is, of course, always a slight risk of injury to some third party with consequent financial liability. Policies can be obtained to cover all third party, fire, accident, burglary, and other risks at moderate premiums.

### Railway Rates for Conveyance of Cars.

A car will only be received for transport by passenger train if it is uncharged with petrol, oil, or electricity, though, regarding the latter, the ordinary ignition accumulators are allowed to be carried.

The charge for conveyance on open trucks by passenger train at owner's risk is usually 6d. per mile, but the Highland and Great North of Scotland Railways charge 7d. per mile. At Company's risk the charges are 25 per cent. above the owner's risk rate. For a covered truck an extra charge of 5/- is made when the distance does not exceed 50 miles, or 10/- if more than 50 miles.

## Official Sign Posts.

 LEADING BRITISH AUTOMOBILE  
 AND AERONAUTICAL CLUBS
 

---

ROYAL AUTOMOBILE CLUB, Pall Mall,  
 London, W.

LADIES' AUTOMOBILE CLUB, Claridge's Hotel,  
 London, W.

AUTOMOBILE ASSOCIATION AND MOTOR  
 UNION, Whitcomb Street, London, W.

BROOKLANDS AUTOMOBILE RACING CLUB,  
 Carlton House, Regent Street, London, W.

AERO CLUB, 116, Piccadilly, London, W.

AERONAUTICAL SOCIETY, 53, Victoria Street,  
 London, S.W.

AERIAL LEAGUE OF G. B. AND I., Carlton  
 House, Regent Street, London, W.

INSTITUTION OF AUTOMOBILE ENGINEERS,  
 Queen Anne's Gate, Westminster, London, S.W.

SCOTTISH AUTOMOBILE CLUB, 163, West George  
 Street, Glasgow.

IRISH AUTOMOBILE CLUB, 34, Dawson Street,  
 Dublin.

---

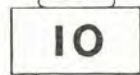

(1.) For 10 miles an hour or lower limit of speed, a white ring 18 inches in diameter, with plate below giving limit in figures.

(2.) For a road closed to motor cars, a red disc, 18 inches in diameter.

(3.) For caution (dangerous corners, cross roads, etc.), a hollow red equilateral triangle, with 18 inch sides.

(4.) All other notices to be on diamond-shaped boards.

INDEX MARK	COUNTY OR BOROUGH COUNCIL.	INDEX MARK	COUNTY OR BOROUGH COUNCIL
A.	London.	C.K.	Preston.
A.A.	Southampton.	C.L.	Norwich.
A.B.	Worcestershire.	C.M.	Birkenhead.
A.C.	Warwick.	C.N.	Gateshead.
A.D.	Gloucestershire.	C.O.	Plymouth.
A.E.	Bristol.	C.P.	Halifax.
A.F.	Cornwall.	C.R.	Southampton.
A.H.	Norfolk.	C.T.	Kesteven (Lines.).
A.I.	Meath.	C.U.	South Shields.
A.J.	Yorkshire.	C.W.	Burnley.
A.K.	Bradford.	C.X.	Huddersfield.
A.L.	Nottinghamshire.	C.Y.	Swansea.
A.M.	Wiltshire.	D.	Kent.
A.N.	West Ham.	D.A.	Wolverhampton.
A.O.	Cumberland.	D.B.	Stockport.
A.P.	Sussex (East).	D.C.	Middlesbrough.
A.R.	Hertfordshire.	D.E.	Pembrokeshire.
A.S.	Nairn.	D.F.	Northampton.
A.T.	Kingston-on-Hull.	D.H.	Walsall.
A.U.	Nottingham	D.I.	Roscommon.
A.W.	Salop.	D.J.	St. Helens.
A.X.	Monmouth.	D.K.	Rochdale.
A.Y.	Leicestershire.	D.L.	Isle of Wight.
B.	Lancashire.	D.M.	Flintshire.
B.A.	Salford.	D.N.	York.
B.B.	Newcastle-on-Tyne.	D.O.	Holland (Lines.).
B.C.	Leicester.	D.P.	Reading.
B.D.	Northamptonshire.	D.R.	Devonport.
B.E.	Lindsey (Lines.).	D.S.	Peebles.
B.H.	Bucks.	D.U.	Coventry.
B.I.	Monaghan.	D.W.	Newport (Mon.).
B.J.	Suffolk (East).	D.X.	Ipswich.
B.K.	Portsmouth.	D.Y.	Hastings.
B.L.	Berkshire.	E.	Staffordshire.
B.M.	Bedfordshire.	E.A.	West Bromwich.
B.N.	Bolton.	E.B.	Isle of Ely.
B.O.	Cardiff.	E.C.	Westmoreland.
B.P.	Sussex (West).	E.D.	Warrington.
B.R.	Sunderland.	E.E.	Grimby.
B.S.	Orkney.	E.F.	West Hartlepool.
B.T.	Yorkshire (E.R.).	E.H.	Stoke-on-Trent.
B.U.	Oldham.	E.I.	Sligo.
B.W.	Oxfordshire.	E.J.	Cardiganshire.
B.X.	Carmarthen.	E.K.	Wigan.
B.Y.	Croydon.	E.L.	Bournemouth.
C.	Yorkshire (W.R.).	E.M.	Bootle.
C.A.	Denbighshire.	E.N.	Bury.
C.B.	Blackburn.	E.O.	Barrow-in-Furness.
C.C.	Carnarvonshire.	E.P.	Montgomeryshire.
C.D.	Brighton.	E.S.	Perth.
C.E.	Cambridgeshire.	E.T.	Rotherham.
C.F.	Suffolk (West).	E.U.	Breconshire.
C.H.	Derby.	E.W.	Huntingdonshire.
C.I.	Queen's County.	E.X.	Great Yarmouth.
C.J.	Herefordshire.	E.Y.	Anglesey.

INDEX MARK	COUNTY OR BOROUGH COUNCIL	INDEX MARK	COUNTY OR BOROUGH COUNCIL
F.	Essex.	L.D.	London.
F.A.	Burton-on-Trent.	L.N.	London.
F.B.	Bath.	L.I.	West Meath.
F.C.	Oxford.	L.S.	Selkirk.
F.D.	Dudley.	M.	Cheshire.
F.E.	Lincoln.	M.I.	Wexford.
F.F.	Merionethshire.	M.S.	Stirling.
F.H.	Gloucester.	N.	Manchester.
F.I.	Tipperary (N.R.).	N.I.	Wicklow.
F.J.	Exeter.	N.S.	Sutherland.
F.K.	Worcester.	O.	Birmingham.
F.L.	Peterborough.	O.I.	Belfast.
F.M.	Chester.	O.S.	Wigtown.
F.N.	Canterbury.	P.	Surrey.
F.O.	Radnorshire.	P.I.	Cork.
F.P.	Rutland.	P.S.	Zetland.
F.R.	Blackpool.	R.	Derbyshire.
F.T.	Tynemouth.	R.I.	Dublin.
F.X.	Dorset.	R.S.	Aberdeen.
F.Y.	Southport.	S.	Edinburgh.
G.	Glasgow.	S.A.	Aberdeenshire.
H.	Middlesex.	S.B.	Argyll.
H.C.	Eastbourne.	S.D.	Ayr.
H.I.	Tipperary (S.R.).	S.E.	Banff.
H.S.	Renfrew.	S.H.	Berwick.
I.A.	Antrim.	S.J.	Bute.
I.B.	Armagh.	S.K.	Cairness.
I.C.	Carlow.	S.L.	Clackmannan.
I.D.	Cavan.	S.M.	Dumfries.
I.E.	Clare.	S.N.	Dumbarton.
I.F.	Co. Cork.	S.O.	Elgin.
I.H.	Donegal.	S.P.	Fife.
I.J.	Down.	S.R.	Forfar.
I.K.	Dublin.	S.S.	Haddington.
I.L.	Fermanagh.	S.T.	Inverness.
I.M.	Galway.	S.U.	Kincardine.
I.N.	Kerry.	S.V.	Kinross.
I.O.	Kildare.	S.W.	Kirkcubright.
I.P.	Kilkenny.	S.X.	Linlithgow.
I.R.	King's County.	S.Y.	Midlothian.
I.T.	Leitrim.	T.	Devon.
I.U.	Limerick.	T.I.	Limerick.
I.W.	Londonderry.	T.S.	Dundee.
I.X.	Longford.	U.	Leeds.
I.Y.	Louth.	U.I.	Londonderry.
I.Z.	Mayo.	U.S.	Govan.
J.	Durham.	V.	Lanark.
J.I.	Tyrone.	V.S.	Greenock.
J.S.	Ross and Cromarty.	W.	Sheffield.
K.	Liverpool.	W.I.	Waterford.
K.I.	Co. Waterford.	W.S.	Leith.
K.S.	Roxburgh.	X.	Northumberland.
L.	Glanorgan.	X.S.	Paisley.
L.A.	London.	Y.	Somerset.
L.B.	London.	Y.S.	Partick.
L.C.	London.		



## DISTANCE TABLE.

Distance by road from London to :—

TOWN	MILES	TOWN	MILES
Aberdare .. .. .	191	Cambridge .. .. .	53
Aberdovey .. .. .	214	Canterbury .. .. .	55
Abergavenny .. .. .	146	Cardiff .. .. .	159
Aberystwyth .. .. .	209	Cardigan .. .. .	238
Acerington .. .. .	208	Carlisle .. .. .	300
Aldershot .. .. .	35	Carmarthen .. .. .	213
Ambleside .. .. .	268	Carmarvon .. .. .	236
Andover .. .. .	64	Chatham .. .. .	30
Appleby .. .. .	272	Chelmsford .. .. .	30
Asecot .. .. .	25	Cheltenham .. .. .	95
Aylesbury .. .. .	39	Chepstow .. .. .	131
Banbury .. .. .	70	Chester .. .. .	181
Bangor .. .. .	233	Chesterfield .. .. .	159
Barnmouth .. .. .	219	Chichester .. .. .	65
Barnsley .. .. .	177	Chorley .. .. .	204
Barnstaple .. .. .	192	Colechester .. .. .	52
Barrow-in-Furness .. .. .	281	Coventry .. .. .	92
Basingstoke .. .. .	46	Crewe .. .. .	161
Bath .. .. .	106	Cromer .. .. .	130
Bedford .. .. .	51	Darlington .. .. .	241
Berwick .. .. .	337	Dartmouth .. .. .	215
Beverley .. .. .	227	Darwen .. .. .	219
Bicester .. .. .	55	Dayentry .. .. .	72
Bideford .. .. .	201	Derby .. .. .	126
Birkenhead .. .. .	196	Devonport .. .. .	215
Birmingham .. .. .	110	Doncaster .. .. .	153
Blackburn .. .. .	215	Dover .. .. .	71
Blackpool .. .. .	233	Droitwich .. .. .	111
Bodmin .. .. .	232	Dunstable .. .. .	34
Bognor .. .. .	63	Durham .. .. .	259
Bolton .. .. .	198	Eastbourne .. .. .	63
Bournemouth .. .. .	103	Edinburgh .. .. .	395
Bradford .. .. .	200	Ely .. .. .	68
Brecon .. .. .	165	Epping .. .. .	18
Bridgnorth .. .. .	139	Epsom .. .. .	15
Bridlington .. .. .	135	Evesham .. .. .	113
Bridport .. .. .	135	Exeter .. .. .	169
Brighton .. .. .	52	Exmouth .. .. .	181
Bristol .. .. .	119	Falmouth .. .. .	266
Bromsgrove .. .. .	111	Felixstowe .. .. .	84
Buckingham .. .. .	56	Fleetwood .. .. .	243
Bude .. .. .	224	Flint .. .. .	195
Builth .. .. .	171	Folkestone .. .. .	70
Burnley .. .. .	215	Frome .. .. .	103
Burton .. .. .	125	Glasgow .. .. .	397
Bury .. .. .	196	Glastonbury .. .. .	130
Bury St. Edmunds .. .. .	71	Gloucester .. .. .	102
Buxton .. .. .	164	Goole .. .. .	183

TAMPA BAY  
DISTANCE TABLE.  
AUTOMOBILE MUSEUM

Distance by road from London to :—

TOWN	MILES	TOWN	MILES
Grantham .. .. .	111	Margate .. .. .	71
Gravesend .. .. .	22	Matlock .. .. .	142
Gt. Grimsby .. .. .	176	Merthyr Tydfil .. .. .	165
Gt. Yarmouth .. .. .	124	Middlesbro' .. .. .	244
Guildford .. .. .	28	Milford .. .. .	219
Halifax .. .. .	204	Mold .. .. .	203
Hanley .. .. .	150	Monmouth .. .. .	129
Harrogate .. .. .	206	Montgomery .. .. .	174
Hartlepool .. .. .	255	Morecambe .. .. .	238
Harwich .. .. .	73	Morpeth .. .. .	288
Hastings .. .. .	62	Nantwich .. .. .	161
Haverfordwest .. .. .	242	Neath .. .. .	196
Helston .. .. .	273	Newark .. .. .	125
Hereford .. .. .	131	Newbury .. .. .	56
Hertford .. .. .	23	Newcastle-under-Lyme .. .. .	148
Hitchin .. .. .	38	Newcastle-on-Tyne .. .. .	273
Holyhead .. .. .	258	Newhaven .. .. .	60
Honiton .. .. .	152	Newmarket .. .. .	62
Horsham .. .. .	37	Newport (Mon.) .. .. .	147
Huddersfield .. .. .	197	Newquay .. .. .	255
Hull .. .. .	219	North Shields .. .. .	280
Hunstanton .. .. .	113	Northallerton .. .. .	225
Huntingdon .. .. .	60	Northampton .. .. .	66
Hfracombe .. .. .	203	Norwich .. .. .	110
Ipswich .. .. .	70	Nottingham .. .. .	124
Keighley .. .. .	211	Onkham .. .. .	96
Kendal .. .. .	255	Oldham .. .. .	196
Keswick .. .. .	302	Oswestry .. .. .	176
Kidderminster .. .. .	121	Oxford .. .. .	54
King's Lynn .. .. .	97	Padstow .. .. .	246
Knaresboro' .. .. .	200	Pembroke .. .. .	245
Lancaster .. .. .	234	Penrith .. .. .	284
Launceston .. .. .	210	Penzance .. .. .	282
Leeds .. .. .	196	Peterborough .. .. .	80
Leicester .. .. .	98	Plymouth .. .. .	213
Leominster .. .. .	136	Pontefract .. .. .	177
Lichfield .. .. .	117	Pontypool .. .. .	151
Lincoln .. .. .	135	Portsmouth .. .. .	73
Liskeard .. .. .	225	Preston .. .. .	213
Liverpool .. .. .	202	Ramsgate .. .. .	72
Llandudno .. .. .	229	Reading .. .. .	39
Llanelli .. .. .	224	Redruth .. .. .	265
Llangollen .. .. .	188	Reigate .. .. .	22
Louth .. .. .	160	Rhyl .. .. .	215
Lowestoft .. .. .	114	Ripon .. .. .	215
Ludlow .. .. .	147	Rochdale .. .. .	201
Macclesfield .. .. .	174	Rochester .. .. .	29
Maidstone .. .. .	35	Ross .. .. .	118
Malvern .. .. .	117	Rugby .. .. .	84
Manchester .. .. .	188	Rye .. .. .	63



### DISTANCE TABLE.

Distance by road from London to:—

TOWN	MILES	TOWN	MILES
St. Albans .. .. .	21	Thirsk .. .. .	217
St. Helens .. .. .	194	Tiverton .. .. .	162
St. Ives, Cornwall .. .. .	291	Torquay .. .. .	192
Salisbury .. .. .	81	Truro .. .. .	256
Scarborough .. .. .	237	Tunbridge Wells .. .. .	38
Selby .. .. .	182	Uttoxeter .. .. .	134
Shaftesbury .. .. .	101	Wakefield .. .. .	181
Sheffield .. .. .	162	Walsall .. .. .	125
Shipley .. .. .	203	Warwick .. .. .	90
Shrewsbury .. .. .	153	Wellington .. .. .	147
Southampton .. .. .	76	Wells .. .. .	125
Southport .. .. .	216	Welshpool .. .. .	171
Southsea .. .. .	73	West Bromwich .. .. .	115
South Shields .. .. .	279	West Hartlepool .. .. .	253
Stafford .. .. .	135	Weston-super-Mare .. .. .	142
Stockport .. .. .	183	Weymouth .. .. .	128
Stoke-on-Trent .. .. .	148	Whitby .. .. .	243
Stourbridge .. .. .	128	Wigan .. .. .	196
Stratford-on-Avon .. .. .	90	Winchester .. .. .	63
Sunderland .. .. .	270	Windsor .. .. .	22
Swansea .. .. .	204	Wolverhampton .. .. .	123
Swindon .. .. .	83	Worcester .. .. .	110
Tamworth .. .. .	110	Worthing .. .. .	56
Taunton .. .. .	141	Yarmouth .. .. .	124
Tavistock .. .. .	207	Yeovil .. .. .	123
Teignmouth .. .. .	185	York .. .. .	196
Tewkesbury .. .. .	103		



### DISTANCE TABLE.

Distance by road from Edinburgh to:—

TOWN	MILES	TOWN	MILES
Aberdeen .. .. .	122	Haddington .. .. .	17
Airdrie .. .. .	33	Hawick .. .. .	51
Alloa .. .. .	30	Inverness .. .. .	186
Arbroath .. .. .	79	Jedburgh .. .. .	48
Aviemore .. .. .	124	John O'Groats .. .. .	293
Banff .. .. .	168	Kelso .. .. .	44
Berwick .. .. .	58	Kingussie .. .. .	111
Blair Atholl .. .. .	75	Kinross .. .. .	23
Callander .. .. .	52	Kirkcaldy .. .. .	14
Carlisle .. .. .	94	Lanark .. .. .	34
Coatbridge .. .. .	35	Leven .. .. .	23
Crieff .. .. .	47	Linlithgow .. .. .	17
Cupar .. .. .	32	Melrose .. .. .	37
Dingwall .. .. .	177	Moffat .. .. .	52
Dumfries .. .. .	73	Montrose .. .. .	92
Dunbar .. .. .	28	Nairn .. .. .	172
Dunblane .. .. .	42	Newport .. .. .	43
Dundee .. .. .	63	Oban .. .. .	125
Dunfermline .. .. .	18	Peebles .. .. .	23
Dunkeld .. .. .	57	Perth (via Queensferry) .. .. .	44
Duns .. .. .	45	Perth (via Stirling) .. .. .	70
Elgin .. .. .	194	Peterhead .. .. .	156
Elie .. .. .	32	Pitlochry .. .. .	68
Falkirk .. .. .	25	St. Andrews .. .. .	37
Forfar .. .. .	70	Selkirk .. .. .	39
Forres .. .. .	182	Stirling .. .. .	36
Fraserburgh .. .. .	165	Stonehaven .. .. .	108
Galashiels .. .. .	33	Strathpeffer .. .. .	181
Glasgow .. .. .	44	Tain .. .. .	203
Grantown .. .. .	141	Thurso .. .. .	283
Greenlaw .. .. .	38	Wick .. .. .	276

## DISTANCE TABLE.

Distance by road from Glasgow to:—

TOWN	MILES	TOWN	MILES
Abingdon .. .. .	38	Greenock .. .. .	23
Airdrie .. .. .	11	Gourock .. .. .	26
Annan .. .. .	96	Hamilton .. .. .	12
Ardrossan .. .. .	52	Helensburgh .. .. .	24
Arrochar .. .. .	37	Inveraray .. .. .	60
Ayr .. .. .	33	Killin .. .. .	68
Balachulish .. .. .	94	Kilmarnock .. .. .	21
Ballantrae .. .. .	66	Kilsyth .. .. .	13
Balloch .. .. .	20	Lanark .. .. .	26
Beattock .. .. .	57	Large .. .. .	40
Beith .. .. .	19	Lesmahagow .. .. .	23
Bellshill .. .. .	10	Lockerbie .. .. .	71
Biggar .. .. .	36	Maybole .. .. .	41
Carlisle .. .. .	95	Motherwell .. .. .	12
Castle Douglas .. .. .	84	New Cumnock .. .. .	42
Coatbridge .. .. .	9	New Galloway .. .. .	70
Crianlarich .. .. .	55	Oban .. .. .	100
Crieff .. .. .	49	Paisley .. .. .	7
Cumnock .. .. .	36	Peebles .. .. .	51
Dalmally .. .. .	72	Perth .. .. .	61
Dalry .. .. .	68	Portpatrick .. .. .	92
Dumbarton .. .. .	15	Renfrew .. .. .	6
Dumfries .. .. .	80	Stirling .. .. .	27
Dunblane .. .. .	33	Stranraer .. .. .	84
Dundee .. .. .	83	Thornhill .. .. .	65
Fairlie .. .. .	43	Tyndrum .. .. .	60
Falkirk .. .. .	23	Uddingston .. .. .	7
Fort Augustus .. .. .	137	Wemyss Bay .. .. .	34
Fort William .. .. .	105	Wigtown .. .. .	91
Garelochhead .. .. .	31	Wishaw .. .. .	16
Girvan .. .. .	54		

## DISTANCE TABLE.

Distance by road from Dublin to:—

TOWN	MILES	TOWN	MILES
Arklow .. .. .	52	Killarney .. .. .	213
Athlone .. .. .	78	Kinsale .. .. .	173
Athy .. .. .	44	Limerick .. .. .	119
Ballinasloe .. .. .	95	Londonderry .. .. .	150
Bantry .. .. .	214	Longford .. .. .	80
Belfast .. .. .	102	Loughrea .. .. .	116
Birr, or Parsonstown .. .. .	82	Maryborough .. .. .	53
Bray .. .. .	13	Mullingar .. .. .	52
Carlow .. .. .	53	Naas .. .. .	21
Carriek-on-Shannon .. .. .	98	Navan .. .. .	29
Cashel .. .. .	98	New Ross .. .. .	88
Cavan .. .. .	68	Portarlington .. .. .	46
Clifden .. .. .	182	Rathdrum .. .. .	36
Clonmel .. .. .	105	Rosecommon .. .. .	90
Cork .. .. .	156	Sligo .. .. .	149
Drogheda .. .. .	30	Tipperary .. .. .	110
Dundalk .. .. .	52	Trillick .. .. .	179
Dungarvon .. .. .	131	Trim .. .. .	27
Ennis .. .. .	142	Tullamore .. .. .	59
Enniscorthy .. .. .	81	Waterford .. .. .	102
Fermoy .. .. .	133	Westport .. .. .	159
Galway .. .. .	135	Wexford .. .. .	95
Kenmare .. .. .	233	Wicklow .. .. .	36
Kildare .. .. .	33	Youghal .. .. .	133
Kilkenny .. .. .	73		

### DISTANCE TABLE.

Distance by road from Belfast to:—

TOWN	MILES	TOWN	MILES
Antrim .. .. .	17	Dundalk .. .. .	51
Armagh .. .. .	37	Dungannon .. .. .	42
Athlone .. .. .	182	Dungiven .. .. .	53
Ballina .. .. .	138	Enniskillen .. .. .	88
Ballinasloe .. .. .	166	Galway .. .. .	195
Ballycastle .. .. .	155	Larne .. .. .	21
Ballymena .. .. .	67	Limavady .. .. .	63
Ballyshannon .. .. .	28	Lisburn .. .. .	8
Banbridge .. .. .	115	Londonderry .. .. .	73
Bangor .. .. .	24	Lurgan .. .. .	21
Belturbet .. .. .	14	Maghera .. .. .	40
Boncrana .. .. .	79	Monaghan .. .. .	55
Bushmills .. .. .	87	Moville .. .. .	92
Bundoran .. .. .	66	Mullingar .. .. .	115
Carrick-on-Shannon .. .. .	119	Newcastle .. .. .	31
Carrickfergus .. .. .	116	Newry .. .. .	38
Cavan .. .. .	10	Omagh .. .. .	69
Coleraine .. .. .	84	Port Ballintrae .. .. .	54
Cookstown .. .. .	52	Portadown .. .. .	26
Donaghadee .. .. .	46	Portrush .. .. .	58
Donegal .. .. .	22	Randalstown .. .. .	22
Downpatrick .. .. .	116	Strabane .. .. .	88
Drogheda .. .. .	22	Sligo .. .. .	156
Dublin .. .. .	73	Westport .. .. .	219
	102	Whitehead .. .. .	15



### MILLIMETRES AND INCHES.

Mm.	Inches.	Mm.	Inches.	Mm.	Inches.	Mm.	Inches.
1	0·0394	26	1·0236	51	2·0079	76	2·9922
2	0·0787	27	1·0630	52	2·0473	77	3·0315
3	0·1181	28	1·1024	53	2·0866	78	3·0709
4	0·1575	29	1·1417	54	2·1260	79	3·1103
5	0·1968	30	1·1811	55	2·1654	80	3·1496
6	0·2362	31	1·2205	56	2·2047	81	3·1890
7	0·2756	32	1·2598	57	2·2441	82	3·2284
8	0·3150	33	1·2992	58	2·2835	83	3·2677
9	0·3543	34	1·3386	59	2·3228	84	3·3071
10	0·3937	35	1·3780	60	2·3622	85	3·3465
11	0·4331	36	1·4173	61	2·4016	86	3·3859
12	0·4724	37	1·4567	62	2·4410	87	3·4252
13	0·5118	38	1·4961	63	2·4803	88	3·4646
14	0·5512	39	1·5354	64	2·5197	89	3·5040
15	0·5906	40	1·5748	65	2·5591	90	3·5433
16	0·6299	41	1·6142	66	2·5984	91	3·5827
17	0·6693	42	1·6536	67	2·6378	92	3·6221
18	0·7087	43	1·6929	68	2·6772	93	3·6614
19	0·7480	44	1·7323	69	2·7166	94	3·7008
20	0·7874	45	1·7717	70	2·7559	95	3·7402
21	0·8268	46	1·8110	71	2·7953	96	3·7796
22	0·8661	47	1·8504	72	2·8347	97	3·8189
23	0·9055	48	1·8898	73	2·8740	98	3·8583
24	0·9449	49	1·9291	74	2·9134	99	3·8977
25	0·9843	50	1·9685	75	2·9528	100	3·9370

### INCHES AND MILLIMETRES.

Inches.	0	$\frac{1}{16}$	$\frac{1}{8}$	$\frac{3}{16}$	$\frac{1}{2}$	$\frac{5}{16}$	$\frac{3}{8}$	$\frac{7}{16}$
0	0·0	1·6	3·2	4·8	6·4	7·9	9·5	11·1
1	25·4	27·0	28·6	30·2	31·7	33·3	34·9	36·5
2	50·8	52·4	54·0	55·6	57·1	58·7	60·3	61·9
3	76·2	77·8	79·4	81·0	82·5	84·1	85·7	87·3
4	101·6	103·2	104·8	106·4	108·0	109·5	111·1	112·7
5	127·0	128·6	130·2	131·8	133·4	134·9	136·5	138·1
6	152·4	154·0	155·6	157·2	158·8	160·3	161·9	163·5

Inches.	$\frac{1}{2}$	$\frac{9}{16}$	$\frac{5}{8}$	$\frac{11}{16}$	$\frac{3}{4}$	$\frac{13}{16}$	$\frac{7}{8}$	$\frac{15}{16}$
0	12·7	14·3	15·9	17·5	19·1	20·6	22·2	23·8
1	38·1	39·7	41·3	42·9	44·4	46·0	47·6	49·2
2	63·5	65·1	66·7	68·3	69·8	71·4	73·0	74·6
3	88·9	90·5	92·1	93·7	95·2	96·8	98·4	100·0
4	114·3	115·9	117·5	119·1	120·7	122·2	123·8	125·4
5	139·7	141·3	142·9	144·5	146·1	147·6	149·2	150·8
6	165·1	166·7	168·3	169·9	171·5	173·0	174·6	176·2

## MILES AND KILOMETRES.

Kilo.	Miles.	Kilo.	Miles.	Kilo.	Miles.	Kilo.	Miles.
1	$1\frac{1}{8}$	20	$12\frac{3}{4}$	38	$23\frac{3}{4}$	56	$34\frac{1}{2}$
2	$1\frac{1}{4}$	21	13	39	$24\frac{1}{2}$	57	$35\frac{1}{2}$
3	$1\frac{3}{8}$	22	$13\frac{1}{2}$	40	$24\frac{3}{4}$	58	36
4	$2\frac{1}{4}$	23	$14\frac{1}{2}$	41	$25\frac{1}{2}$	59	$36\frac{1}{2}$
5	$3\frac{1}{8}$	24	$14\frac{3}{4}$	42	$26\frac{1}{2}$	60	$37\frac{1}{2}$
6	$3\frac{3}{8}$	25	$15\frac{1}{2}$	43	$26\frac{3}{4}$	70	$43\frac{1}{2}$
7	$4\frac{1}{4}$	26	$16\frac{1}{2}$	44	$27\frac{1}{2}$	80	$49\frac{1}{2}$
8	$5\frac{1}{8}$	27	$16\frac{3}{4}$	45	28	90	$55\frac{1}{2}$
9	$5\frac{3}{8}$	28	$17\frac{1}{2}$	46	$28\frac{1}{2}$	100	$62\frac{1}{2}$
10	$6\frac{1}{4}$	29	18	47	$29\frac{1}{2}$	200	$124\frac{1}{2}$
11	$6\frac{3}{8}$	30	$18\frac{1}{2}$	48	$29\frac{3}{4}$	300	$186\frac{3}{4}$
12	$7\frac{1}{4}$	31	$19\frac{1}{2}$	49	30	400	$248\frac{1}{2}$
13	$8\frac{1}{8}$	32	$19\frac{3}{4}$	50	$31\frac{1}{2}$	500	$310\frac{1}{2}$
14	$8\frac{3}{8}$	33	$20\frac{1}{2}$	51	$31\frac{3}{4}$	600	$372\frac{3}{4}$
15	$9\frac{1}{8}$	34	$21\frac{1}{2}$	52	$32\frac{1}{2}$	700	435
16	10	35	$21\frac{3}{4}$	53	$32\frac{3}{4}$	800	497
17	$10\frac{1}{2}$	36	$22\frac{1}{2}$	54	$33\frac{1}{2}$	900	$559\frac{1}{2}$
18	$11\frac{1}{4}$	37	23	55	$34\frac{1}{2}$	1000	621
19	$11\frac{3}{8}$						

## CONVERSION OF METRIC INTO ENGLISH MEASURE.

1 millimetre is approximately  $\frac{1}{25}$  inch and is exactly .03937 inch.  
 1 centimetre is approximately  $\frac{1}{25}$  inch and is exactly .3937 inch.  
 1 metre is approximately  $39\frac{1}{4}$  inches and is exactly 1.0936 yards.  
 1 kilometre is approximately  $\frac{5}{8}$  mile and is exactly .6213 mile.  
 1 kilogramme is approximately  $2\frac{1}{4}$  lbs. and is exactly 2.21 lbs.  
 1 litre is approximately  $1\frac{1}{4}$  pints and is exactly 1.76 pints.

To convert metres to yards, multiply by 70 and divide by 64.

To convert kilometres to miles, multiply by 5 and divide by 8 (approx.).

To convert litres to pints, multiply by 88 and divide by 50.

To convert grams to ounces, multiply by 567 and divide by 20.

To find the cubical contents of a motor cylinder, square the diameter (or bore) multiply by 0.7854 and multiply the result by the stroke.



## SPEED TABLE.

Time of One Mile.		Miles per Hour.	Time of One Mile.		Miles per Hour.	Time of One Mile.		Miles per Hour.
Min.	Sec.		Min.	Sec.		Min.	Sec.	
0	40	90	1	22	43.9	2	12	27.3
0	41	87.18	1	23	43.3	2	15	26.7
0	42	85.6	1	24	42.8	2	18	26.1
0	43	83.8	1	25	42.4	2	21	25.5
0	44	81.8	1	26	41.9	2	24	25
0	45	80	1	27	41.4	2	27	24.5
0	46	78.2	1	28	40.9	2	30	24
0	47	76.6	1	29	40.4	2	33	23.6
0	48	75	1	30	40	2	36	23.1
0	49	73.4	1	31	39.6	2	39	22.6
0	50	72	1	32	39.1	2	42	22.2
0	51	70.6	1	33	38.7	2	45	21.8
0	52	69.2	1	34	38.3	2	48	21.4
0	53	68	1	35	37.9	2	51	21.1
0	54	66.8	1	36	37.5	2	54	20.7
0	55	65.4	1	37	37.1	2	57	20.3
0	56	64.2	1	38	36.7	3	0	20
0	57	63.2	1	39	36.4	3	6	19.4
0	58	62	1	40	36	3	12	18.8
0	59	61	1	41	35.7	3	18	18.2
1	0	60	1	42	35.3	3	24	17.7
1	1	59	1	43	34.9	3	30	17.1
1	2	58	1	44	34.6	3	36	16.7
1	3	57.1	1	45	34.3	3	42	16.2
1	4	56.3	1	46	34	3	48	15.7
1	5	55.4	1	47	33.7	3	54	15.4
1	6	54.5	1	48	33.4	4	0	15
1	7	53.7	1	49	33	4	6	14.6
1	8	53	1	50	32.7	4	12	14.3
1	9	52.2	1	51	32.4	4	18	13.9
1	10	51.4	1	52	32.1	4	24	13.6
1	11	50.7	1	53	31.8	4	30	13.3
1	12	50	1	54	31.6	4	36	13
1	13	49.4	1	55	31.3	4	42	12.8
1	14	48.6	1	56	31	4	48	12.5
1	15	48	1	57	30.8	4	54	12.2
1	16	47.4	1	58	30.5	5	0	12
1	17	46.7	1	59	30.2	5	12	11.5
1	18	46.2	2	0	30	5	24	11.1
1	19	45.6	2	3	29.2	5	36	10.7
1	20	45	2	6	28.6	5	48	10.3
1	21	44.4	2	9	27.9	6	0	10

PERSONAL MEMORANDA.

Name .....

Address .....

Nearest Rly. Sta. ....

Telegraphic Address .....

Telephone Number .....

MOTOR MEMORANDA.

Date of Purchase .....

Car No. ....

Registration Number .....

Motor Driver's License Number .....

CALENDAR 1911.

JANUARY.			FEBRUARY.			MARCH.		
S	1	8 15 22 29	S	5	12 19 26	S	5	12 19 26
M	2	9 16 23 30	M	6	13 20 27	M	6	13 20 27
Th	3	10 17 24 31	Th	7	14 21 28	Th	7	14 21 28
W	4	11 18 25	W	8	15 22 29	W	8	15 22 29
Th	5	12 19 26	Th	9	16 23 30	Th	9	16 23 30
F	6	13 20 27	F	10	17 24 31	F	10	17 24 31
S	7	14 21 28	S	11	18 25	S	11	18 25
APRIL.			MAY.			JUNE.		
S	30	2 9 16 23	S	7	14 21 28	S	4	11 18 25
M	1	8 15 22 29	M	8	15 22 29	M	5	12 19 26
Th	2	10 17 24 31	Th	9	16 23 30	Th	6	13 20 27
W	3	11 18 25	W	10	17 24 31	W	7	14 21 28
Th	4	11 18 25	Th	11	18 25	Th	8	15 22 29
W	5	12 19 26	W	12	19 26	W	9	16 23 30
Th	6	13 20 27	Th	13	20 27	Th	10	17 24 31
F	7	14 21 28	F	14	21 28	F	11	18 25
S	1	8 15 22 29	S	15	22 29	S	12	19 26
JULY.			AUGUST.			SEPTEMBER.		
S	30	2 9 16 23	S	6	13 20 27	S	3	10 17 24
M	31	3 10 17 24	M	7	14 21 28	M	4	11 18 25
Th	1	4 11 18 25	Th	8	15 22 29	Th	5	12 19 26
W	2	5 12 19 26	W	9	16 23 30	W	6	13 20 27
Th	3	6 13 20 27	Th	10	17 24 31	Th	7	14 21 28
W	4	11 18 25	W	11	18 25	W	8	15 22 29
Th	5	12 19 26	Th	12	19 26	Th	9	16 23 30
F	6	13 20 27	F	13	20 27	F	10	17 24 31
S	1	8 15 22 29	S	14	21 28	S	11	18 25
OCTOBER.			NOVEMBER.			DECEMBER.		
S	1	8 15 22 29	S	5	12 19 26	S	31	3 10 17 24
M	2	9 16 23 30	M	6	13 20 27	M	1	4 11 18 25
Th	3	10 17 24 31	Th	7	14 21 28	Th	2	5 12 19 26
W	4	11 18 25	W	8	15 22 29	W	3	6 13 20 27
Th	5	12 19 26	Th	9	16 23 30	Th	4	11 18 25
W	6	13 20 27	W	10	17 24 31	W	5	12 19 26
Th	7	14 21 28	Th	11	18 25	Th	6	13 20 27
F	8	15 22 29	F	12	19 26	F	7	14 21 28
S	9	16 23 30	S	13	20 27	S	8	15 22 29

CALENDAR 1912.

JANUARY.			FEBRUARY.			MARCH.		
S	7	14 21 28	S	4	11 18 25	S	31	3 10 17 24
M	1	8 15 22 29	M	5	12 19 26	M	1	4 11 18 25
Th	2	9 16 23 30	Th	6	13 20 27	Th	2	5 12 19 26
W	3	10 17 24 31	W	7	14 21 28	W	3	6 13 20 27
Th	4	11 18 25	Th	8	15 22 29	Th	4	11 18 25
W	5	12 19 26	W	9	16 23 30	W	5	12 19 26
Th	6	13 20 27	Th	10	17 24 31	Th	6	13 20 27
F	7	14 21 28	F	11	18 25	F	7	14 21 28
S	8	15 22 29	S	12	19 26	S	8	15 22 29
APRIL.			MAY.			JUNE.		
S	7	14 21 28	S	5	12 19 26	S	30	2 9 16 23
M	1	8 15 22 29	M	6	13 20 27	M	1	3 10 17 24
Th	2	9 16 23 30	Th	7	14 21 28	Th	2	4 11 18 25
W	3	10 17 24 31	W	8	15 22 29	W	3	5 12 19 26
Th	4	11 18 25	Th	9	16 23 30	Th	4	6 13 20 27
W	5	12 19 26	W	10	17 24 31	W	5	7 14 21 28
Th	6	13 20 27	Th	11	18 25	Th	6	8 15 22 29
F	7	14 21 28	F	12	19 26	F	7	9 16 23 30
S	8	15 22 29	S	13	20 27	S	8	10 17 24 31
JULY.			AUGUST.			SEPTEMBER.		
S	7	14 21 28	S	4	11 18 25	S	1	8 15 22 29
M	1	8 15 22 29	M	5	12 19 26	M	2	9 16 23 30
Th	2	9 16 23 30	Th	6	13 20 27	Th	3	10 17 24 31
W	3	10 17 24 31	W	7	14 21 28	W	4	11 18 25
Th	4	11 18 25	Th	8	15 22 29	Th	5	12 19 26
W	5	12 19 26	W	9	16 23 30	W	6	13 20 27
Th	6	13 20 27	Th	10	17 24 31	Th	7	14 21 28
F	7	14 21 28	F	11	18 25	F	8	15 22 29
S	8	15 22 29	S	12	19 26	S	9	16 23 30
OCTOBER.			NOVEMBER.			DECEMBER.		
S	6	13 20 27	S	3	10 17 24	S	1	8 15 22 29
M	7	14 21 28	M	4	11 18 25	M	2	9 16 23 30
Th	1	8 15 22 29	Th	5	12 19 26	Th	3	10 17 24 31
W	2	9 16 23 30	W	6	13 20 27	W	4	11 18 25
Th	3	10 17 24 31	Th	7	14 21 28	Th	5	12 19 26
W	4	11 18 25	W	8	15 22 29	W	6	13 20 27
Th	5	12 19 26	Th	9	16 23 30	Th	7	14 21 28
F	6	13 20 27	F	10	17 24 31	F	8	15 22 29
S	7	14 21 28	S	11	18 25	S	9	16 23 30

Lighting-up Time is One Hour after Sunset.

Day of M. W.	MEMORANDA.	Miles Run.	Sun	
			Rises.	Sets.
			H. M.	H. M.
1 W	.....		6.49	5.37
2 Th	.....		6.47	5.38
3 F	.....		6.45	5.40
4 S	.....		6.43	5.42
5 <del>S</del>	.....		6.41	5.44
6 M	.....		6.39	5.46
7 Tu	.....		6.36	5.47
8 W	.....		6.34	5.49
9 Th	.....		6.32	5.51
10 F	.....		6.29	5.53
11 S	.....		6.26	5.55
12 <del>S</del>	.....		6.24	5.57
13 M	.....		6.22	5.58
14 Tu	.....		6.20	6. 0
15 W	.....		6.17	6. 2
16 Th	.....		6.15	6. 4
17 F	.....		6.13	6. 6
18 S	.....		6.10	6. 7
19 <del>S</del>	.....		6. 8	6. 8
20 M	.....		6. 7	6.10
21 Tu	.....		6. 5	6.12
22 W	.....		6. 2	6.13
23 Th	.....		6. 0	6.15
24 F	.....		5.57	6.17
25 S	.....		5.55	6.18
26 <del>S</del>	.....		5.53	6.20
27 M	.....		5.51	6.22
28 Tu	.....		5.48	6.23
29 W	.....		5.46	6.25
30 Th	.....		5.44	6.27
31 F	.....		5.41	6.28



Lighting-up Time is One Hour after Sunset.

Day of M. W.	MEMORANDA.	Miles Run.	Sun	
			Rises.	Sets.
			H. M.	H. M.
1 S	.....		5.39	6.30
2 <del>S</del>	.....		5.37	6.32
3 M	.....		5.35	6.34
4 Tu	.....		5.32	6.35
5 W	.....		5.30	6.36
6 Th	.....		5.28	6.38
7 F	.....		5.25	6.39
8 S	.....		5.23	6.41
9 <del>S</del>	.....		5.21	6.43
10 M	.....		5.19	6.45
11 Tu	.....		5.17	6.46
12 W	.....		5.15	6.48
13 Th	.....		5.12	6.50
14 F	.....		5.10	6.52
15 S	.....		5. 8	6.53
16 <del>S</del>	.....		5. 6	6.55
17 M	.....		5. 4	6.57
18 Tu	.....		5. 2	6.58
19 W	.....		5. 0	7. 0
20 Th	.....		4.58	7. 1
21 F	.....		4.56	7. 3
22 S	.....		4.54	7. 5
23 <del>S</del>	.....		4.51	7. 6
24 M	.....		4.49	7. 7
25 Tu	.....		4.48	7. 9
26 W	.....		4.46	7.11
27 Th	.....		4.44	7.13
28 F	.....		4.42	7.15
29 S	.....		4.39	7.16
30 <del>S</del>	.....		4.37	7.18

Lighting-up Time is One Hour after Sunset.

Day of M. W.	MEMORANDA.	Miles Run.	Sun	
			Rises. H. M.	Sets. H. M.
1 M	.....		4.35	7.20
2 Tu	.....		4.33	7.22
3 W	.....		4.32	7.24
4 Th	.....		4.30	7.25
5 F	.....		4.28	7.27
6 S	.....		4.26	7.28
7 <del>S</del>	.....		4.24	7.29
8 M	.....		4.23	7.30
9 Tu	.....		4.21	7.31
10 W	.....		4.20	7.33
11 Th	.....		4.18	7.35
12 F	.....		4.16	7.37
13 S	.....		4.14	7.39
14 <del>S</del>	.....		4.13	7.40
15 M	.....		4.11	7.42
16 Tu	.....		4.10	7.43
17 W	.....		4. 8	7.45
18 Th	.....		4. 7	7.46
19 F	.....		4. 6	7.47
20 S	.....		4. 4	7.48
21 <del>S</del>	.....		4. 3	7.50
22 M	.....		4. 2	7.51
23 Tu	.....		4. 1	7.52
24 W	.....		4. 0	7.54
25 Th	.....		3.59	7.56
26 F	.....		3.58	7.58
27 S	.....		3.56	7.59
28 <del>S</del>	.....		3.55	8. 0
29 M	.....		3.54	8. 1
30 Tu	.....		3.53	8. 2
31 W	.....		3.52	8. 3



Lighting-up Time is One Hour after Sunset.

Day of M. W.	MEMORANDA.	Miles Run.	Sun	
			Rises. H. M.	Sets. H. M.
1 Th	.....		3.51	8. 4
2 F	.....		3.50	8. 5
3 S	.....		3.50	8. 6
4 <del>S</del>	.....		3.49	8. 7
5 M	.....		3.48	8. 8
6 Tu	.....		3.47	8. 9
7 W	.....		3.46	8.10
8 Th	.....		3.46	8.11
9 F	.....		3.46	8.12
10 S	.....		3.46	8.12
11 <del>S</del>	.....		3.45	8.13
12 M	.....		3.45	8.14
13 Tu	.....		3.45	8.15
14 W	.....		3.44	8.16
15 Th	.....		3.44	8.16
16 F	.....		3.44	8.16
17 S	.....		3.44	8.16
18 <del>S</del>	.....		3.44	8.18
19 M	.....		3.44	8.18
20 Tu	.....		3.44	8.18
21 W	.....		3.44	8.18
22 Th	.....		3.45	8.19
23 F	.....		3.45	8.19
24 S	.....		3.45	8.19
25 <del>S</del>	.....		3.45	8.19
26 M	.....		3.45	8.19
27 Tu	.....		3.46	8.19
28 W	.....		3.47	8.19
29 Th	.....		3.47	8.19
30 F	.....		3.48	8.18

JULY, 1911.

Lighting-up Time is One Hour after Sunset.

Day of M. W.	MEMORANDA.	Miles Run.	Sun	
			Rises. H. M.	Sets. H. M.
1 S			3.48	8.18
2 #			3.49	8.18
3 M			3.50	8.17
4 Tr			3.51	8.17
5 W			3.51	8.16
6 Tu			3.52	8.16
7 F			3.53	8.15
8 S			3.54	8.15
9 #			3.55	8.14
10 M			3.56	8.13
11 Tr			3.57	8.13
12 W			3.58	8.12
13 Tu			3.59	8.11
14 F			4. 0	8.10
15 S			4. 1	8. 9
16 #			4. 2	8. 8
17 M			4. 4	8. 7
18 Tr			4. 5	8. 6
19 W			4. 6	8. 5
20 Tu			4. 7	8. 4
21 F			4. 9	8. 3
22 S			4.10	8. 1
23 #			4.11	8. 0
24 M			4.13	7.59
25 Tr			4.14	7.57
26 W			4.15	7.56
27 Tu			4.17	7.55
28 F			4.18	7.53
29 S			4.20	7.52
30 #			4.21	7.50
31 M			4.23	7.48



AUGUST, 1911.

Lighting-up Time is One Hour after Sunset.

Day of M. W.	MEMORANDA.	Miles Run.	Sun	
			Rises. H. M.	Sets. H. M.
1 Tr			4.24	7.47
2 W			4.26	7.45
3 Th			4.27	7.44
4 F			4.29	7.42
5 S			4.30	7.40
6 #			4.32	7.38
7 M			4.33	7.37
8 Tr			4.35	7.35
9 W			4.36	7.33
10 Tu			4.38	7.31
11 F			4.40	7.29
12 S			4.41	7.27
13 #			4.43	7.26
14 M			4.44	7.24
15 Tr			4.46	7.22
16 W			4.48	7.20
17 Tu			4.49	7.18
18 F			4.51	7.16
19 S			4.52	7.14
20 #			4.54	7.12
21 M			4.55	7.10
22 Tr			4.57	7. 7
23 W			4.59	7. 5
24 Tu			5. 0	7. 3
25 F			5. 2	7. 1
26 S			5. 3	6.59
27 #			5. 5	6.57
28 M			5. 7	6.55
29 Tr			5. 8	6.53
30 W			5.10	6.50
31 Th			5.11	6.48



Lighting-up Time is One Hour after Sunset.

Day of M. W.	MEMORANDA.	Miles Run.	Sun	
			Rises.	Sets.
1	F		H. M. 5.13	H. M. 6.46
2	S		5.15	6.44
3	<del>S</del>		5.16	6.41
4	M		5.18	6.39
5	Tr		5.19	6.37
6	W		5.21	6.35
7	Thu		5.23	6.32
8	F		5.24	6.30
9	S		5.26	6.28
10	<del>S</del>		5.27	6.26
11	M		5.29	6.23
12	Tr		5.31	6.21
13	W		5.32	6.19
14	Thu		5.34	6.17
15	F		5.35	6.14
16	S		5.37	6.12
17	<del>S</del>		5.38	6.10
18	M		5.40	6. 7
19	Tr		5.42	6. 5
20	W		5.43	6. 3
21	Thu		5.45	6. 0
22	F		5.47	5.58
23	S		5.48	5.56
24	<del>S</del>		5.50	5.53
25	M		5.51	5.51
26	Tr		5.53	5.49
27	W		5.55	5.47
28	Thu		5.56	5.44
29	F		5.58	5.42
30	S		6 0	5.40



Lighting-up Time is One Hour after Sunset.

Day of M. W.	MEMORANDA.	Miles Run.	Sun	
			Rises.	Sets.
1	<del>S</del>		H. M. 6. 1	H. M. 5.37
2	M		6. 3	5.35
3	Tr		6. 5	5.33
4	W		6. 6	5.31
5	Thu		6. 8	5.28
6	F		6. 9	5.26
7	S		6.11	5.24
8	<del>S</del>		6.13	5.22
9	M		6.14	5.19
10	Tr		6.16	5.17
11	W		6.18	5.15
12	Thu		6.20	5.13
13	F		6.21	5.11
14	S		6.22	5. 8
15	<del>S</del>		6.25	5. 6
16	M		6.26	5. 4
17	Tr		6.28	5. 2
18	W		6.30	5. 0
19	Thu		6.32	4.58
20	F		6.33	4.56
21	S		6.35	4.54
22	<del>S</del>		6.37	4.52
23	M		6.38	4.50
24	Tr		6.40	4.48
25	W		6.42	4.46
26	Thu		6.44	4.44
27	F		6.46	4.42
28	S		6.47	4.40
29	<del>S</del>		6.49	4.38
30	M		6.51	4.36
31	Tr		6.53	4.34

Lighting-up Time is One Hour after Sunset.

Day of M. W.	MEMORANDA.	Miles Run.	Sun	
			Rises.	Sets.
			H. M.	H. M.
1 W	.....		6.55	4.32
2 Th	.....		6.56	4.30
3 F	.....		6.58	4.29
4 S	.....		7. 0	4.27
5 *	.....		7. 2	4.25
6 M	.....		7. 3	4.23
7 Tu	.....		7. 5	4.22
8 W	.....		7. 7	4.20
9 Th	.....		7. 9	4.18
10 F	.....		7.11	4.17
11 S	.....		7.13	4.15
12 *	.....		7.14	4.14
13 M	.....		7.16	4.12
14 Tu	.....		7.18	4.11
15 W	.....		7.19	4.10
16 Th	.....		7.21	4. 8
17 F	.....		7.23	4. 7
18 S	.....		7.24	4. 6
19 *	.....		7.26	4. 4
20 M	.....		7.28	4. 3
21 Tu	.....		7.30	4. 2
22 W	.....		7.31	4. 1
23 Th	.....		7.33	4. 0
24 F	.....		7.34	3.59
25 S	.....		7.36	3.58
26 *	.....		7.38	3.57
27 M	.....		7.39	3.56
28 Tu	.....		7.41	3.55
29 W	.....		7.42	3.54
30 Th	.....		7.44	3.53



Lighting-up Time is One Hour after Sunset.

Day of M. W.	MEMORANDA.	Miles Run.	Sun	
			Rises.	Sets.
			H. M.	H. M.
1 F	.....		7.45	3.53
2 S	.....		7.46	3.52
3 *	.....		7.48	3.52
4 M	.....		7.49	3.51
5 Tu	.....		7.51	3.51
6 W	.....		7.52	3.50
7 Th	.....		7.53	3.50
8 F	.....		7.54	3.49
9 S	.....		7.55	3.49
10 *	.....		7.57	3.49
11 M	.....		7.58	3.49
12 Tu	.....		7.59	3.49
13 W	.....		8. 0	3.49
14 Th	.....		8. 1	3.49
15 F	.....		8. 1	3.49
16 S	.....		8. 2	3.49
17 *	.....		8. 3	3.49
18 M	.....		8. 4	3.50
19 Tu	.....		8. 4	3.50
20 W	.....		8. 5	3.50
21 Th	.....		8. 6	3.51
22 F	.....		8. 6	3.51
23 S	.....		8. 7	3.52
24 *	.....		8. 7	3.52
25 M	.....		8. 7	3.53
26 Tu	.....		8. 8	3.54
27 W	.....		8. 8	3.54
28 Th	.....		8. 8	3.55
29 F	.....		8. 8	3.56
30 S	.....		8. 9	3.57
31 *	.....		8. 9	3.58

Lighting-up Time is One Hour after Sunset.

Day of M. W.	MEMORANDA.	Miles Run.	Sun	
			Rises. H. M.	Sets. H. M.
1 M	.....	.....	8. 8	3.59
2 Tu	.....	.....	8. 8	4. 0
3 W	.....	.....	8. 8	4. 1
4 Th	.....	.....	8. 7	4. 2
5 F	.....	.....	8. 7	4. 3
6 S	.....	.....	8. 7	4. 5
7 <del>S</del>	.....	.....	8. 6	4. 6
8 M	.....	.....	8. 6	4. 8
9 Tu	.....	.....	8. 5	4. 9
10 W	.....	.....	8. 5	4.10
11 Th	.....	.....	8. 4	4.12
12 F	.....	.....	8. 4	4.13
13 S	.....	.....	8. 3	4.14
14 <del>S</del>	.....	.....	8. 2	4.16
15 M	.....	.....	8. 2	4.17
16 Tu	.....	.....	8. 1	4.19
17 W	.....	.....	8. 0	4.20
18 Th	.....	.....	7.59	4.22
19 F	.....	.....	7.58	4.24
20 S	.....	.....	7.56	4.26
21 <del>S</del>	.....	.....	7.55	4.27
22 M	.....	.....	7.55	4.29
23 Tu	.....	.....	7.54	4.30
24 W	.....	.....	7.52	4.32
25 Th	.....	.....	7.51	4.33
26 F	.....	.....	7.50	4.35
27 S	.....	.....	7.49	4.37
28 <del>S</del>	.....	.....	7.47	4.39
29 M	.....	.....	7.46	4.40
30 Tu	.....	.....	7.44	4.42
31 W	.....	.....	7.43	4.44



Lighting-up Time is One Hour after Sunset.

Day of M. W.	MEMORANDA.	Miles Run.	Sun	
			Rises. H. M.	Sets. H. M.
1 Th	.....	.....	7.42	4.46
2 F	.....	.....	7.40	4.48
3 S	.....	.....	7.39	4.50
4 <del>S</del>	.....	.....	7.37	4.52
5 M	.....	.....	7.35	4.54
6 Tu	.....	.....	7.33	4.55
7 W	.....	.....	7.32	4.57
8 Th	.....	.....	7.30	4.58
9 F	.....	.....	7.28	5. 0
10 S	.....	.....	7.26	5. 2
11 <del>S</del>	.....	.....	7.25	5. 4
12 M	.....	.....	7.23	5. 6
13 Tu	.....	.....	7.21	5. 8
14 W	.....	.....	7.19	5.10
15 Th	.....	.....	7.17	5.12
16 F	.....	.....	7.15	5.13
17 S	.....	.....	7.13	5.15
18 <del>S</del>	.....	.....	7.11	5.17
19 M	.....	.....	7.10	5.19
20 Tu	.....	.....	7. 8	5.21
21 W	.....	.....	7. 6	5.23
22 Th	.....	.....	7. 4	5.25
23 F	.....	.....	7. 2	5.27
24 S	.....	.....	6.59	5.28
25 <del>S</del>	.....	.....	6.57	5.30
26 M	.....	.....	6.55	5.31
27 Tu	.....	.....	6.53	5.33
28 W	.....	.....	6.51	5.35
29 Th	.....	.....	6.49	5.37

TABLE SHOWING THE VARIATION OF SUNRISE AND SUNSET  
IN DIFFERENT PARTS OF THE BRITISH ISLES.

USE OF TABLE: To find the time for lighting lamps add one hour to the time of sunset at Greenwich given in the Calendar (see pages 102 to 113), and add or subtract the minutes given in the following Table for the time of the year and the locality desired.

The numbers refer to the 16th day of each month; those for any intermediate day can readily be found by proportion.

PLACE.	JANUARY		FEBRUARY		MARCH		APRIL		MAY		JUNE	
	Rises	Sets	Rises	Sets	Rises	Sets	Rises	Sets	Rises	Sets	Rises	Sets
	m.	m.	m.	m.	m.	m.	m.	m.	m.	m.	m.	m.
Aberdeen	+37	-21	+22	-6	+10	+6	-5	+21	-19	+35	-30	+46
Birmingham	+12	+4	+10	+6	+8	+8	+6	+10	+4	+12	+2	+14
Bristol	+10	+10	+10	+10	+10	+10	+10	+10	+10	+10	+10	+10
Cambridge	+3	-3	+1	-1	0	0	-1	+1	-3	+3	-4	+4
Cardiff	+13	+13	+13	+13	+13	+13	+13	+13	+13	+13	+13	+13
Carlisle	+28	-4	+20	+4	+13	+11	+4	+20	-4	+28	-10	+34
Cork	+36	+32	+35	+33	+34	+34	+33	+35	+32	+36	+31	+37
Derby	+12	0	+9	+3	+6	+6	+3	+9	0	+12	-3	+15
Dundee	+37	-13	+25	-1	+14	+10	0	+24	-12	+36	-21	+45
Edinburgh	+35	-9	+24	+2	+14	+12	+3	+23	-8	+34	-16	+42
Exeter	+11	+17	+12	+16	+14	+14	+16	+12	+18	+10	+19	+9
Glasgow	+38	-4	+28	+6	+18	+16	+7	+27	-4	+38	-11	+45
Hull	+11	-9	+6	-4	+2	0	-4	+6	-10	+12	-14	+16
Inverness	+48	-14	+32	+2	+19	+15	+3	+31	-12	+46	-23	+57
Leicester	+10	0	+8	+2	+6	+4	+3	+7	0	+10	-2	+12
Liverpool	+21	+3	+16	+8	+12	+12	+8	+16	+3	+21	-1	+25
Manchester	+18	0	+13	+5	+9	+9	+5	+13	0	+18	-4	+22
Newcastle	+23	-11	+14	-2	+7	+5	-2	+14	-10	+22	-16	+28
Norwich	0	-10	-2	-8	-4	-6	-7	-3	-10	0	-12	+2
Nottingham	+11	-1	+8	+2	+5	+5	+2	+8	-1	+11	-4	+14
Oxford	+6	+4	+5	+5	+5	+5	+5	+5	+4	+6	+3	+7
Perth	+38	-10	+26	+2	+16	+12	+3	+25	-9	+37	-18	+46
Plymouth	+12	+22	+14	+20	+16	+18	+19	+15	+22	+12	+24	+10
Portsmouth	+1	+7	+2	+6	+4	+4	+6	+2	+8	0	+9	-1
Sheffield	+15	-3	+10	+2	+6	+6	+2	+10	-3	+15	-7	+19
York	+15	-7	+10	-2	+5	+3	-1	+9	-8	+16	-12	+20

TABLE SHOWING THE VARIATION OF SUNRISE AND SUNSET  
IN DIFFERENT PARTS OF THE BRITISH ISLES.

USE OF TABLE: To find the time for lighting lamps add one hour to the time of sunset at Greenwich given in the Calendar (see pages 102 to 113), and add or subtract the minutes given in the following Table for the time of the year and the locality desired.

The numbers refer to the 16th day of each month; those for any intermediate day can readily be found by proportion.

PLACE.	JULY		AUGUST		SEPTEMBER		OCTOBER		NOVEMBER		DECEMBER	
	Rises	Sets	Rises	Sets	Rises	Sets	Rises	Sets	Rises	Sets	Rises	Sets
	m.	m.	m.	m.	m.	m.	m.	m.	m.	m.	m.	m.
Aberdeen	-24	+40	-10	+26	+5	+11	+19	-3	+32	-6	+43	-27
Birmingham	+3	+13	+5	+11	+8	+8	+10	+6	+12	+4	+14	+2
Bristol	+10	+10	+10	+10	+10	+10	+10	+10	+10	+10	+10	+10
Cambridge	-4	+4	-2	+2	0	0	+1	-1	+2	-2	+4	-4
Cardiff	+13	+13	+13	+13	+13	+13	+13	+13	+13	+13	+13	+13
Carlisle	-6	+30	+1	+23	+10	+14	+19	+5	+26	-2	+32	-8
Cork	+31	+37	+33	+35	+34	+34	+35	+33	+36	+32	+37	+31
Derby	-2	+14	+2	+10	+5	+7	+8	+4	+11	+1	+14	-2
Dundee	-15	+39	-4	+28	+9	+15	+22	+2	+34	-10	+42	-18
Edinburgh	-11	+37	-1	+27	+10	+16	+22	+4	+33	-7	+41	-15
Exeter	+18	+10	+16	+12	+14	+14	+12	+16	+11	+17	+10	+18
Glasgow	-7	+41	+3	+31	+14	+20	+26	+8	+37	-3	+45	-11
Hull	-11	+13	-6	+8	0	+2	+5	-3	+10	-8	+14	-12
Inverness	-18	+52	-2	+36	+14	+20	+28	+6	+44	-10	+54	-20
Leicester	-1	+11	+2	+8	+5	+5	+7	+3	+9	+1	+12	-2
Liverpool	+2	+22	+6	+18	+11	+13	+16	+8	+20	+4	+23	+1
Manchester	-1	+19	+3	+15	+8	+10	+13	+5	+17	+1	+20	-2
Newcastle	-12	+24	-5	+17	+4	+8	+13	-1	+21	-9	+27	-15
Norwich	-11	+1	-8	-2	-5	-5	-3	-7	-1	-9	+2	-12
Nottingham	-3	+13	+1	+9	+4	+6	+7	+3	+10	0	+13	-3
Oxford	+3	+7	+4	+6	+5	+5	+5	+5	+6	+4	+7	+3
Perth	-12	+40	-1	+29	+11	+17	+23	+5	+35	-7	+44	-16
Plymouth	+23	+11	+21	+13	+18	+16	+15	+19	+13	+21	+11	+23
Portsmouth	+8	0	+6	+2	+4	+4	+2	+6	+1	+7	0	+8
Sheffield	+4	+16	0	+12	+5	+7	+10	+2	+14	-2	+17	-5
York	-9	+17	-4	+12	+2	+6	+9	-1	+14	-6	+18	-10

## INDEX.

	PAGE
Accumulators, Care of .. .. .	24
Air Pump .. .. .	13
Bodies, Treatment of .. .. .	71
Brakes .. .. .	50 and 69
Calendar .. .. .	101
Carburettor .. .. .	19
Clubs, List of .. .. .	86
Clutch .. .. .	35
Clutch Brake .. .. .	36
Clutch Adjustment .. .. .	36
Cylinder Heads .. .. .	13
Depots, Daimler .. .. .	67
Description of the Working Parts .. .. .	4
Distance Tables, London .. .. .	90
.. .. . Edinburgh .. .. .	93
.. .. . Glasgow .. .. .	94
.. .. . Dublin .. .. .	95
.. .. . Belfast .. .. .	96
Driving Notes .. .. .	68
Electric Lamps .. .. .	33
Engine .. .. .	4
Engine Lubrication .. .. .	10
Fan .. .. .	18
Firing Order .. .. .	33
Fuel Feed System .. .. .	14
Gear Box .. .. .	39
Gear Changing .. .. .	69
Grease, Daimler .. .. .	54
Hints to Drivers .. .. .	70
Hubs, Wheel .. .. .	47
Ignition—	
38 h.p. Accumulator .. .. .	23
38 h.p. Magneto .. .. .	25
Dual Magneto .. .. .	28
Index Marks .. .. .	88
Insurance .. .. .	85
Landaulette Hood, to Lower .. .. .	72
Lighting-up Tables .. .. .	102 to 115
Lubrication .. .. .	54
Lubricating Oil, Daimler .. .. .	54
Magneto, Bosch .. .. .	26
.. C.A.V. Dual .. .. .	28
.. Bosch Dual .. .. .	29



	PAGE
Magneto Troubles .. .. .	31
Magneto Drive .. .. .	32
Measurement Tables .. .. .	97
Memoranda .. .. .	100
Misfiring Cylinder, to Locate .. .. .	89
Oil Indicator—to clean glass .. .. .	79
Overhauling .. .. .	67
Overheating .. .. .	17
Petrol Filter .. .. .	22
Petrol Storage .. .. .	85
Petrol Tank Capacity .. .. .	22
Plan of Car .. .. .	2 and 3
Radiator .. .. .	16
Railway Rates .. .. .	85
Rear Axle .. .. .	41
Registration and Licensing .. .. .	81
Sign Posts .. .. .	87
Silencer .. .. .	53
Speed Table .. .. .	99
Spiral Suspension .. .. .	52
Spring Clips .. .. .	53
Springs .. .. .	51
Steering Gear .. .. .	42
Swivel Shackles .. .. .	51
Transmission Gear .. .. .	35
Trembler Coil Adjustment .. .. .	24
Troubles and Their Location .. .. .	74
Tyres, Care of .. .. .	55 and 73
Tyres Pressure Table .. .. .	73
Universal Coupling .. .. .	38 and 41
Unusual Noises .. .. .	89
Valves .. .. .	12
Washing the Car .. .. .	71
Water Pump .. .. .	15
Wheels .. .. .	44
Wheel Hubs .. .. .	47

